

UNIVERSAL  
LIBRARY

**OU 166611**

UNIVERSAL  
LIBRARY

ELEMENTARY CHEMISTRY  
PROGRESSIVE LESSONS IN  
EXPERIMENT AND THEORY

I

WILSON AND HEDLEY

THIRD EDITION

OSMANIA UNIVERSITY LIBRARY

Call No. 542/W 57 E <sup>22-1</sup> Accession No. 8703

Author Wilson. F. R. L.

Title *Elementary Chemistry* 1910.

This book should be returned on or before the date last marked below.



# ELEMENTARY CHEMISTRY

PROGRESSIVE LESSONS IN  
EXPERIMENT AND THEORY

## PART I

BY

F. R. L. WILSON, M.A.

CHEMISTRY MASTER AT CHARTERHOUSE

AND

G. W. HEDLEY, M.A.

HEAD SCIENCE MASTER, MILITARY AND CIVIL SIDE  
CHELTENHAM COLLEGE

THIRD EDITION

OXFORD

AT THE CLARENDON PRESS

1910

HENRY FROWDE, M.A.  
PUBLISHER TO THE UNIVERSITY OF OXFORD  
LONDON, EDINBURGH, NEW YORK  
TORONTO AND MELBOURNE

## PREFACE

THE object of this book is to provide a school course of practical training in Chemistry, suitable for those studying the subject as an integral part of their general education, and at the same time to lay a solid foundation for such as may require to specialize in it later.

The ultimate object of the authors is the cultivation of a scientific habit of mind in the pupils, through the medium of Chemistry, rather than the mere acquisition of the facts of the science.

Changes in the syllabuses of most examining bodies have now made the achievement of this aim possible, not only for the few who are independent of external examinations, but for the many whose future career depends on success in these examinations.

To meet these changed conditions of school work many books of great merit have appeared, but, in the opinion of the present authors, too little systematic effort has been made to induce pupils to think for themselves, and insufficient care taken to relieve the teacher from the immensely increased burden of work which is involved in the method of individual investigation.

To train the pupils in thoughtful habits of study is, in any subject, one of the teacher's most difficult tasks. In some cases this difficulty may be due to lack of interest, but in science there is less danger of this than of the absorption of so much interest in experimental details as to leave little for the real object of the work.

A course of investigation which may be admirable for a single boy in charge of a private tutor, or for a small

class continuously under the same teacher, is apt to fail with larger classes, when the capacities of individuals vary widely and when a pupil passes from one teacher to another almost every term.

The teacher therefore requires to be liberated as much as possible from the necessity of dealing with details of manipulation, so that he may be able to insist that each member of the class shall think about and interpret the experimental results. The requirements for a book aiming at this object seem to be:—

- (a) Such clear directions for the performance of experiments and the observation of results as shall be intelligible without further explanation;
- (b) Some definite means of inducing thought about the work done;
- (c) Opportunity for applying original thought to the solution of problems.

To carry out this plan, it has been thought well to begin most chapters with a list of *preliminary questions*, which are to be answered from general knowledge. In this way a pupil begins by thinking out what he already knows about the subject and reduces his ideas (correct or otherwise) to writing; the necessity for experiment is thus often made evident, and the answers to the questions form a useful record of the extent of his previous knowledge.

Following on these preliminary questions are full and plain *directions* for experiments and observations, but without any indication of the results expected.

After the practical work a list of questions is given in order to elicit the chief *conclusions* which are derivable from the experiment; answers to these are always to be shown up before proceeding to the next experiment.

The teacher, being freed from attending to points of manipulation, will have time to check the results of each



pupil and to see that correct answers to the questions are obtained, *whilst the class is in the laboratory.*

Nothing beyond a diagram, record of observations, and answers to the questions, is expected in the Laboratory Notebook, a full account of the whole experiment being reserved for evening work, when it is to be carefully written in a Fair Notebook. The soundness of the work having already been tested in the laboratory, no more than a cursory inspection of Fair Notebooks is required to ensure neatness and adequacy of description.

Another serious difficulty in work of this kind is that of keeping a class together, in order that the class-room work, which naturally resolves itself into a discussion of the results obtained in the laboratory, may come at the right time for appreciation by the whole class. Variation in the speed of working of different pupils, their absence, and the unavoidable promotion of pupils at different stages into the same class, all tend, unless special precautions are taken, to separate the work of individual members to such an extent as may destroy the whole spirit of the scheme.

To meet this difficulty, practical problems have been inserted after most experiments; these can be attempted by the quicker, and omitted by the slower workers at the discretion of the teacher.

A list of additional problems is also given, and these are particularly useful at the beginning of a term for the employment of the more advanced, whilst the others continue the normal course until all have reached the same stage.

It has been thought advisable to divide the book into three parts. Part I is intended for beginners about fourteen years of age, and consists of those portions of mensuration and elementary physics which are an essential preliminary to the study of Chemistry.

Each chapter is complete in itself, and for those who have already done some mensuration, certain portions may be omitted at this stage without interfering with the general sequence.

Some teachers may prefer to postpone experiments on the laws of gases, though our experience shows that they are not beyond the ability of young boys.

Part II introduces more strictly chemical subjects, and deals with combustion, air, nitrogen, oxygen, &c., with simple gravimetric and volumetric experiments.

Elements, compounds and mixtures, chemical and physical change, the composition of water, hydrogen and carbonates, are treated practically, but also with special reference to theory, a point apt to be neglected, and a sufficient basis of quantitative work is laid for a proper understanding of the atomic theory, which is introduced by experiments on the diffusion of gases.

Part III is a continuation of the course in the light of the atomic theory, intended to cover the ground required for a school-leaving certificate, for the new syllabus of the Woolwich and Sandhurst entrance examinations, and others conducted on similar lines.

Whilst laying no claims to originality in the experimental part of the book, the authors venture to hope that the method of treatment will be useful to teachers in diminishing the difficulties of carrying out an extended course of elementary investigation.

The experiments have been tested practically in classes at Charterhouse and at Cheltenham College, and the authors take this opportunity of thanking their colleagues and others who have been kind enough to give them the benefit of their criticism.

F. R. L. W.  
G. W. H.

# CONTENTS

## CHAPTER I

### THE MEASUREMENT OF LENGTH, AREA, AND VOLUME

	PAGE
<i>The metric system of weights and measures</i> . . . . .	1
<i>Tables of the metric system</i> . . . . .	2
<b>The measurement of length.</b>	
<i>Preliminary questions on the measurement of length</i> . . . . .	3
<i>Rules for writing notes</i> . . . . .	4
<b>Practical exercises in the measurement of length.</b>	
Exp. 1. To measure a straight line to $\frac{1}{100}$ of a centimetre . . . . .	6
Exp. 2. To measure the length of a curved line . . . . .	8
Exp. 3. To measure the diameter of a halfpenny . . . . .	10
Exp. 4. To measure the circumference of a penny and of a halfpenny . . . . .	12
<i>The ratio of the circumference to the diameter of a circle</i> . . . . .	14
<b>Special instruments for the accurate measurement of length.</b>	
<i>The vernier</i> . . . . .	15
Exp. 5. To use sliding calipers . . . . .	16
<i>The screw gauge</i> . . . . .	17
Exp. 6. To use the screw gauge . . . . .	18
<i>Examples on the measurement of length. I (a)</i> . . . . .	19
<b>The measurement of area.</b>	
<i>Preliminary questions on the measurement of areas</i> . . . . .	20
Exp. 7. To measure the area of rectangles . . . . .	21
Exp. 8. To measure the area of a circle . . . . .	22
Exp. 9. To find the area of cross-section of a narrow tube, using a wedge . . . . .	24
<i>Examples on the measurement of areas. I (b)</i> . . . . .	25

	PAGE
<b>The measurement of volume.</b>	
<i>Preliminary questions on volume</i> . . . . .	26
Exp. 10. To measure the volume of some regular solids . . . . .	26
<b>Special instruments for the measurement of volumes.</b>	
Exp. 11. To use a measuring jar . . . . .	28
<i>Notes on the use of measuring vessels</i> . . . . .	30
Exp. 12. To find the volume of a metal cylinder, using a measuring jar . . . . .	31
Exp. 13. To use a burette . . . . .	32
Exp. 14. To use a pipette . . . . .	35
<i>Examples on the measurement of volume. I (c)</i> . . . . .	36

## CHAPTER II

### CONSTRUCTION OF SIMPLE APPARATUS

#### Laboratory gas-burners.

Exp. 1. Examination of a Bunsen burner . . . . .	37
Exp. 2. Examination of a bat's-wing burner . . . . .	38

#### Simple glass working.

Exp. 3. To divide narrow glass tubes . . . . .	39
Exp. 4. To break off a jagged end . . . . .	39
Exp. 5. To divide wide glass tubes . . . . .	39
Exp. 6. To round the edges of a glass tube . . . . .	40
Exp. 7. To seal a glass tube . . . . .	41
Exp. 8. To draw out a narrow tube from a wide one . . . . .	41
Exp. 9. To bend glass tubes . . . . .	42
Exp. 10. To bend a glass tube at a given angle . . . . .	43
Exp. 11. To bore a cork . . . . .	44
Exp. 12. To fit up a flask with an exit tube . . . . .	45
Exp. 13. To dry a wet flask quickly . . . . .	45
<i>Hints on fitting up apparatus</i> . . . . .	46
<i>Questions on Chapter II</i> . . . . .	47

## CHAPTER III

## SIMPLE EFFECTS OF HEAT. THE THERMOMETER

	PAGE
<i>Preliminary questions on heat</i> . . . . .	48
Exp. 1. On the conducting power of solids for heat . . . . .	49
Exp. 2. To find whether the volume of water alters on heating . . . . .	50
Exp. 3. Examination of a centigrade thermometer . . . . .	51
Exp. 4. To learn how a thermometer is graduated . . . . .	52
<i>Other methods of graduating thermometers</i> . . . . .	54
<i>Latent heat</i> . . . . .	55
Exp. 5. To show that a liquid loses its latent heat on solidifying . . . . .	56
Exp. 6. To find the melting-point of a solid . . . . .	57
Exp. 7. To find the boiling-point of a liquid . . . . .	59
<i>Questions on Chapter III</i> . . . . .	60

## CHAPTER IV

## THE CHEMICAL BALANCE

Exp. 1. Examination of a box of weights . . . . .	61
Exp. 2. To illustrate the principle of the balance . . . . .	62
Exp. 3. To examine an accurate balance . . . . .	63
<i>Rules for weighing</i> . . . . .	65
Exp. 4. Practice in weighing . . . . .	66
<i>The rider</i> . . . . .	66
<i>Numerical examples. IV</i> . . . . .	68

## CHAPTER V

## THE MEASUREMENT OF DENSITY

<i>Preliminary questions on density</i> . . . . .	69
Exp. 1. To find the weight of 1 c.c. of water at the air temperature . . . . .	70
<i>Remarks on density</i> . . . . .	71
<i>Remarks on specific gravity</i> . . . . .	72
<i>Remarks on relative density</i> . . . . .	74

	PAGE
Exp. 2. To find the relative density of liquids, using a relative density bottle . . . . .	75
Exp. 3. To find the density of shot at the air temperature . . . . .	76
Exp. 4. To compare the weight of a solid in air with its weight when suspended in liquids . . . . .	77
<i>The principle of Archimedes</i> . . . . .	79
Problems on the principle of Archimedes . . . . .	80
Exp. 5. To find the relative density of a liquid, using a U-tube . . . . .	81
Exp. 6. Further experiments with the U-tube . . . . .	82
<i>Pressure exerted by solids and liquids</i> . . . . .	83
<i>Transmission of pressure</i> . . . . .	83
<i>Questions on Chapter V</i> . . . . .	85

## CHAPTER VI

## SOLUTIONS

<i>Preliminary questions on solution</i> . . . . .	87
Exp. 1. To separate (a) suspended, (b) dissolved, solids from the liquid containing them . . . . .	88
<i>Solutions of solids in liquids</i> . . . . .	90
Exp. 2. To obtain pure water from ordinary tap water	92
Exp. 3. To distil liquids with improved apparatus . . . . .	93
<i>The preparation of large quantities of distilled water</i> . . . . .	94
Exp. 4. To show the influence of temperature on the solubility of a solid . . . . .	95
Exp. 5. To test the solubility of various solids in cold and hot water . . . . .	96
Exp. 6. To ascertain the solvent power of other liquids	97
<i>Solubility</i> . . . . .	98
Exp. 7. To find the solubility of a solid in water at different temperatures . . . . .	99
<i>To plot a curve of solubility</i> . . . . .	101
<i>Examples. VI (a)</i> . . . . .	103
Exp. 8. To separate the soluble from the insoluble portion of a mixture of solids, and to find the percentage weight of each present . . . . .	104
Exp. 9. To find whether one liquid can dissolve another	105

## CONTENTS

xi

	PAGE
Exp. 10. To separate a solution of two liquids by fractional distillation . . . . .	106
Exp. 11. To find whether ordinary water contains dissolved air . . . . .	107
Questions. VI (b) . . . . .	108

## CHAPTER VII

### CRYSTALLIZATION

<i>Some remarks on crystals</i> . . . . .	109
Exp. 1. Examination and measurement of common crystals . . . . .	110
Exp. 2. To find out the best conditions for the formation of crystals . . . . .	112
Exp. 3. To grow a large crystal . . . . .	113
<i>Conditions of crystallization</i> . . . . .	114
Exp. 4. To find the effect of heat on certain crystals . . . . .	115
Exp. 5. The effect of heat on other crystals . . . . .	117
<i>Water of crystallization</i> . . . . .	118
<i>Volatility</i> . . . . .	118
Exp. 6. To find the percentage weight of liquid formed by heating certain crystals . . . . .	119
Exp. 7. To separate a mixture of two soluble solids . . . . .	120
Exp. 8. To find the effect of exposing certain crystals to the air . . . . .	121
<i>Efflorescence and deliquescence</i> . . . . .	122
Exp. 9. To form crystals by cooling a melted solid . . . . .	123
Questions on Chapter VII . . . . .	124

## CHAPTER VIII

### SOME PROPERTIES OF AIR

<i>Preliminary questions on air</i> . . . . .	125
Exp. 1. To find out if air has weight . . . . .	126
Exp. 2. To measure the expansion of air between 0°C. and 100°C. . . . .	128
<i>Charles's Law</i> . . . . .	130
<i>Examples on Charles's Law. VIII (a)</i> . . . . .	132
Exp. 3. To show that air can (a) be compressed, (b) exert pressure . . . . .	133

	PAGE
Exp. 4. To measure the pressure of the atmosphere . . . . .	134
<i>The barometer</i> . . . . .	135
Exp. 5. To read the barometric height on a Fortin's barometer . . . . .	136
Exp. 6. To find the pressure required to halve the volume of a given mass of air . . . . .	137
Exp. 7. To find the relation between the pressure and volume of a given mass of air . . . . .	139
<i>Boyle's Law</i> . . . . .	140
<i>Examples on Boyle's Law. VIII (b)</i> . . . . .	141
<i>The alteration of the volume of a gas due to the simultaneous alteration of its temperature and pressure</i> . . . . .	142
<i>Examples. VIII (c)</i> . . . . .	144

## CHAPTER IX

## EVAPORATION, VAPOUR PRESSURE, AND BOILING OF LIQUIDS.

<i>Preliminary questions on evaporation and boiling</i> . . . . .	145
Exp. 1. To find the effect of placing air and liquids in barometers . . . . .	146
<i>Vapour pressure</i> . . . . .	147
<i>Dalton's Law of partial pressures</i> . . . . .	148
<i>Evaporation and ebullition</i> . . . . .	149
Exp. 2. To show the influence of temperature on the pressure of water vapour . . . . .	150
<i>Examples on Chapter IX (a)</i> . . . . .	152

## CHAPTER X

## THE MEASUREMENT OF HEAT. SPECIFIC HEAT

<i>Distinction between heat and temperature</i> . . . . .	153
Exp. 1. To observe the temperature of a mixture of known quantities of warm and cold water . . . . .	154
<i>Unit quantity of heat</i> . . . . .	155
Exp. 2. To observe the temperature of a mixture of known weights of cold water and hot metals . . . . .	157
<i>Specific heat</i> . . . . .	158
<i>Examples on Chapter X</i> . . . . .	160



## CHAPTER XI

IDENTIFICATION OF SUBSTANCES BY THEIR PHYSICAL  
PROPERTIES

	PAGE
<i>The identification of solids</i> . . . . .	161
<i>The identification of liquids</i> . . . . .	162
<i>The identification of gases</i> . . . . .	163
<i>The three physical states of matter</i> . . . . .	163
Problems in identification . . . . .	164
ADDITIONAL PRACTICAL PROBLEMS . . . . .	165
REVISION QUESTIONS, CHAPTERS I-X . . . . .	167

## APPENDIX

<i>Types of verniers</i> . . . . .	171
<i>The spherometer</i> . . . . .	175
Exp. 6 (b), Chap. I. To use a spherometer . . . . .	176
<i>Calibration of tubes and vessels</i> . . . . .	177
Exp. 7, Chap. V. To find the internal dimensions of a piece of narrow glass tube . . . . .	178
Exp. 8, Chap. V. To calibrate a narrow glass tube . . . . .	179
To calibrate burettes, pipettes, measuring jars, &c. . . . .	180
ANSWERS TO EXAMPLES . . . . .	181
INDEX . . . . .	186



# CHAPTER I

## THE MEASUREMENT OF LENGTH, AREA, AND VOLUME

### **The Metric System of Weights and Measures.**

IN all scientific work the weights and measures used are those of the French or Metric system, which in point of simplicity far excels that commonly used in England. The advantage is gained by making a given weight or measure always 10 (or some multiple of 10) times the next lower denomination, instead of 3,  $30\frac{1}{4}$ , or 28 times, as in the English system; so that fractions of the unit of measurement may be easily expressed by decimals. The system is also rendered simpler by discarding special tables for such materials as cloth, hay and straw, metals, &c. On the other hand, it is less convenient for mental arithmetic, since it is more difficult to multiply decimal fractions than vulgar fractions; for example,  $.75 \times .75$  is more difficult to work in the head than  $\frac{3}{4} \times \frac{3}{4}$ .

The adjective 'metric' is derived from the word 'metre'—the name given to the **standard of length**.

This standard is the length at  $0^{\circ}\text{C}.$ <sup>1</sup> of a bar of platinum kept in Paris, and is equal to 39.37 English inches.

The prefixes expressing the divisions of a metre (milli-, centi-, deci-) are derived respectively from the Latin *mille* (1000), *centum* (100), *decem* (10); those expressing the multiples (deka-, hecto-, kilo-) from the Greek *deka* (10), *hekaton* (100), *chilioi* (1000).

<sup>1</sup> This indicates that the platinum is at the temperature of melting ice, i. e. at zero on the centigrade scale (see Chap. III).

The following tables should be learnt by heart:—

### LENGTH.

10 <i>milli</i> -metres (mm.)	= 1 centimetre (cm.) = .01 m.
10 <i>centi</i> -metres	= 1 decimetre (dm.) = .1 m.
10 <i>deci</i> -metres	= 1 metre (m.)
10 metres	= 1 dekametre (Dm.) = 10 m.
10 <i>deka</i> -metres	= 1 hectometre (Hm.) = 100 m.
10 <i>hecto</i> -metres	= 1 kilometre (Km.) = 1000 m.

'Dekametre' is often written 'decametre.'

### AREA.

100 sq. mm.	= 1 sq. cm.
100 sq. cm.	= 1 sq. dm.
100 sq. dm.	= 1 sq. m.
100 sq. m.	= 1 sq. Dm.
100 sq. Dm.	= 1 sq. Hm.
100 sq. Hm.	= 1 sq. Km.

### VOLUME.

1000 cubic millimetres	= 1 cubic centimetre (c.c.)
1000 cubic centimetres	= 1 cubic decimetre (= 1 litre)
1000 cubic decimetres	= 1 cubic metre.

The cubic centimetre (c.c.) and litre (l.) are the most often used.

### MASS.

1 milligram (mg.)	= .001 g.
10 milligrams	= 1 centigram (cg.) = .01 g.
10 centigrams	= 1 decigram (dg.) = .1 g.
10 decigrams	= 1 gram (g.)
10 grams	= 1 dekagram (Dg.) = 10 g.
10 dekagrams	= 1 hectogram (Hg.) = 100 g.
10 hectograms	= 1 kilogram (Kg.) = 1000 g.

### THE MEASUREMENT OF LENGTH.

Everybody has a general idea how to find the length of an object of moderate size by means of a ruler or scale. Easy as it may seem to measure such lengths fairly

accurately in simple cases, it is not so easy to do so *quite* accurately, and, where a scale cannot be used, the problem is distinctly difficult.

In scientific work it is important to make all measurements to a high degree of accuracy, and to take every precaution against mistakes. The **degree of accuracy** to be aimed at depends on the *magnitude* to be measured. No one would think of measuring the distance between two towns to  $\frac{1}{10}$ th of an inch, but in finding the thickness of a wire the measurement should be made to  $\frac{1}{1000}$ th of an inch at least. As a general rule the measurement should be correct to  $\frac{1}{100}$ th or  $\frac{1}{1000}$ th part of the quantity being measured.

### **Preliminary Questions on the Measurement of Length.**

*[Record your present ideas on measurement of length by answering the following questions in your Fair Notebook. You are expected to think out an answer for yourself and not to obtain any help.]*

Explain as carefully as possible how you would obtain an accurate measurement of:—

1. The length of the diagonal of an oblong table<sup>1</sup>.
2. The diameter of a penny.
3. The greatest breadth of the trunk of a living tree.
4. The breadth of a river.
5. The thickness of one page of this book.
6. The circumference of a small circle.
7. The shortest distance along a road between two towns.
8. The internal diameter of a tube.
9. The length of the coast line of England from a map.
10. If you had measured a line as carefully as you could three times, and the results were 6.42 cm., 6.41 cm., 6.44 cm., what would be the probable length?

<sup>1</sup> Copy out Question 1 and then write your answer. Do the same for the other questions.

In attempting answers to the above questions, you will have seen that measurement of length is often no easy matter, and you may have thought of still harder cases, such as the height of a mountain, the diameter of the earth, the distance between two stars, the thickness of a hair.

Even when the greatest care has been taken, it will be found that several measurements of the same length will not agree exactly, although they may be very close together. The question arises as to which result is most likely to be correct. Now as there is no reason to think that any one of them is better than any other, it is fair to suppose that some of the results are too big and others too small. Therefore it is probable that the **average or mean result** will be most accurate. Hence several measurements must be taken, and those widely differing from the majority rejected. The others are to be added together, and the sum total divided by their number so as to obtain the *mean value* of the measurement.

### RULES FOR WRITING NOTES.

The following instructions for taking and writing out notes on experiments should be carefully read through before practical work is begun.

Two notebooks are necessary, one for use in the laboratory, and the other for a more permanent and complete record of the work.

#### **The Laboratory Notebook.**

Whenever possible the notes should be arranged as follows:—

- (1) The number of the experiment and its title.
- (2) A full account of all the observations, not omitting mistakes.

N. B.—Records of weighings and measurements must be made at once.

- (3) A diagram in section of the apparatus used.
- (4) Answers to the questions.

### **The Fair Notebook.**

In this book must be written a full account of the work, the printed directions and the Laboratory Notes being used for guidance. The printed directions must not be copied out as they stand, but used for the purpose of recalling to the mind what was done in the laboratory. The description of the work should be written in the first person, all observations being recorded, together with the conclusions which may be drawn from the experiments.

The Fair Notes should be written in ink, using only one side of the paper, the other being left clear for the insertion of diagrams.

It is very important that the description should be clearly expressed in good English.

The following order is recommended for the Fair Notes:—

- (1) The number and title of the experiment.
- (2) A clearly arranged description of what was done, and a record of observations. Diagrams should be drawn on the opposite page.
- (3) The conclusions which may be drawn from the work. These were included in the Laboratory Notes in the form of answers to questions, but should now be written down as deductions.

PRACTICAL EXERCISES IN THE MEASUREMENT  
OF LENGTH.

*Required for experiments in Chap. I:—H pencil, mathematical instruments, ruler with metric and English scales, set square, millimetre squared paper, thread, wooden blocks and spheres. [Extra requirements for problems are indicated by italics in stating the problem.]*

**Exp. 1. To measure a straight line to  $\frac{1}{100}$  of a centimetre.**

DIRECTIONS.

Draw a fine line on a page in your notebook, and mark off three inches by dividers.

Measure this by means of a metric scale correctly to .1 cm., and estimate to .01 cm.

**Precautions.**

- (a) Place the ruler on its narrow edge.
- (b) Avoid using the end divisions of the scale.
- (c) Keep the eye exactly opposite the left-hand point, and move your head three inches to the right to get it opposite the right-hand point when reading the scale.

Make three measurements using different parts of the scale. If any measurement differs from the others in the first place of decimals, it must be rejected and another made.



## LABORATORY NOTES.

Record your results thus :

1st measurement of 3 in. =	cm.
2nd       "       "       " =	cm.
3rd       "       "       " =	cm.
Total of 3 measurements =	
<i>Average or mean measurement</i> =	
	cm.

**Questions**<sup>1</sup>:—

- (i) Express the result as a decimal of a metre.
- (ii) Calculate the length of 1 inch in centimetres.
- (iii) Give reasons for the precautions **a**, **b**, and **c**.
- (iv) If the eye were kept considerably to the left (or right) of the line, what effect would this have on the result?  
Draw a diagram to illustrate your answer.

## PROBLEMS (I. 1).

1. If the reasons for precautions cannot be given, repeat the measurement, deliberately neglecting each precaution in turn and finally neglect them all. Compare the results with the others.

2. Draw a line 1 inch long. Measure it in centimetres (to .01 cm.) as in Exp. 1, and compare the result with that calculated from Exp. 1. State which you think is likely to be the most accurate, giving reasons.

<sup>1</sup> The questions need not be copied out in either notebook, but answers to them should be numbered in the Laboratory Notebook and shown up before going on to another experiment. In the Fair Notebook incorporate these questions with the corrected answers as *conclusions*—expressing them entirely in your own words.

**Exp. 2. To measure the length of a curved line.**

## DIRECTIONS.

Draw a semicircle of 3.15 cm. radius on a page of your notebook.

Make a small knot at the end of a piece of thread, and place it at one end of the line.

Gradually lay the thread along the line, keeping each section in position with two fingers.

Place the thread along the scale, find its length correct to .1 cm., and estimate to .01 cm.

Make two other similar measurements.

**Precautions.**

Avoid (a) letting the thread slip ;

(b) over-stretching it.

Any other curved line may be measured in a similar way.

## LABORATORY NOTES.

Record your results and find the mean as in Exp. 1.

Express the mean as a decimal of (a) a decimetre and  
(b) a metre.

*Questions*<sup>1</sup>:—(i) Supposing the precautions have been properly taken, would you expect the result to be too large or too small? Give reasons and an enlarged diagram to illustrate them.

(ii) Can you suggest a more accurate way of measuring a curved line?

<sup>1</sup> See footnote, p. 7.

## PROBLEMS (I. 2).

1. Find whether this is a good way for measuring the circumference of a *penny*.

2. Repeat Problem 1, using a marked *wooden sphere* or a *marble*. (This will be wanted again.)

3. Measure the semicircle in Exp. 2 with an *opisometer* or *map-measurer*. Sketch the instrument and describe how it works. Compare the result with the others and explain which method you think most accurate, giving your reasons fully.

**Exp. 3. To measure the diameter of a halfpenny.**

## DIRECTIONS.

*A. Using a metric scale only.* Take the mean of three measurements. State what objections you think the method is open to.

*B. Using wooden blocks and a scale.* Take three rectangular wooden blocks with straight edges; one large ( $X$ ), the others smaller and equal ( $Y$  and  $Z$ ), and place the latter in front of  $X$ , but in close contact with it. Put the halfpenny flat on the bench between  $Y$  and  $Z$  so that it just touches all the blocks.

**Precaution:** See that the edges of both  $Y$  and  $Z$  are flush with that of  $X$ .

Measure the distance between the nearest extremities of  $Y$  and  $Z$  with the scale.

Make three measurements and find the mean.

*C. Using millimetre squared paper.* Place the coin so that its circumference just touches both a thick vertical and a thick horizontal line.

Read off the length of the diameter in two directions at right angles, estimating to  $\frac{1}{10}$ th of a millimetre.

Make two more readings at a different part of the paper.

## LABORATORY NOTES.

Scheme of results of  $A$ ,  $B$ , and  $C$ , calculating the mean of each as in Exp. 1.

Express one result as the decimal of a kilometre.

**Questions**<sup>1</sup>:—(i) Does the halfpenny appear to be a perfect circle? (i. e. are the lengths of two diameters at right angles equal to one another?)

(ii) Which is (a) the most accurate, (b) the most convenient of the three methods?

<sup>1</sup> See footnote, p. 7.

- (iii) Do the results of *B* and *C* agree with that calculated for the length of an inch in Exp. 1 ?
- (iv) What is the length of the diameter in inches ?

## PROBLEMS (I. 3).

1. Assuming that the divisions on your scale are correct, find whether those of the squared paper are equally so. (If there is any discrepancy answer Question (ii) again.)
2. Measure the diameter of a glass tube, using squared paper. [Mark and keep the tube for Prob. 3, p. 13.]
3. Measure the diameter of a sphere, using wooden blocks.

**Exp. 4. To measure the circumference of a penny and a halfpenny<sup>1</sup>.**

### DIRECTIONS.

- A. Make a very small ink dot on the rim of a penny. Place a piece of clean paper on your Laboratory Notebook, and tilt one end of the book with your hand, while the other end rests on the bench. Hold the penny in your other hand, and then let it run down the paper. The rolling coin will leave two small ink dots on the paper. Practise this until you get the coin to roll without sliding or wobbling. Join the two dots by a fine pencil-line, using the ruler, and measure it in millimetres, estimating to  $\frac{1}{8}$  of a millimetre. Repeat twice more. Find the mean of the three results.
- B. Repeat the experiment, using a halfpenny.
- C. Measure the diameter of the penny as accurately as possible in mm. The results of Exp. 3 will give the diameter of the halfpenny.

### LABORATORY NOTES.

Record each measurement as in Exp. 1 and find the *mean* length of the circumference for each coin.

Divide the length of circumference (in mm.) of each coin by its diameter (in mm.), recording thus:—

Coin.	Circumf. in mm.	Diam. in mm.	$\frac{\text{Circumf.}}{\text{Diameter}} = \text{---}$ .
Penny			— = .
Halfpenny			— = .

<sup>1</sup> Wooden disks may be substituted.

**Questions:**—(i) Is the quotient  $\frac{\text{circumference}}{\text{diameter}}$  the same for both coins?

(ii) Do you think the quotient would be the same for a larger circle or not? Give reasons.

### PROBLEMS (I. 4).

1. Repeat Exp. 4, (a) using a thread, (b) rolling the penny along the scale, holding it with your finger, (c) wrapping a strip of paper round the edge of the coin, pricking it where it overlaps with a pin and measuring the distance between the holes. Compare the results and state which method you think is best.

2. Describe a circle of 5 cm. radius. Measure its circumference with thread and find the value of the quotient  $\frac{\text{circumference}}{\text{diameter}}$ .

3. Measure the circumference of the glass tube used in Prob. 2, p. 11, by finding the length of a fine wire which just surrounds the tube five times and dividing by 5. Find the ratio of the circumference to the diameter.

**The ratio of the circumference to the diameter of a circle.**

If Exp. 4 has been done well, the quotient  $\frac{\text{circumference}}{\text{diameter}}$  will have been found in each case to be 3.1416 or  $3\frac{1}{7}$ . This quotient or ratio shows how many times the circumference is as great as the diameter, and is found to be the same for all circles. Since it comes into a great many calculations, it is denoted by a special symbol, viz. the Greek letter  $\pi$ .

If the radius of a circle is called  $r$ , then for this circle

$$\frac{\text{circumference}}{2 r} = \pi,$$

$$\therefore \text{circumference} = 2 \pi r.$$

$\pi$  is called a *constant*, since it expresses the fact that the ratio of the length of the circumference to that of the diameter of any circle is always the same, i.e. it is fixed or constant. 3.1416 is the numerical value of this constant. It is well to remember that a ratio can be expressed either (a) as a vulgar fraction (i.e.  $\frac{22}{7}$ ), or (b) as a quotient (i.e.  $3\frac{1}{7}$  or 3.1416), the latter (b) being obtained from the former by division. It is a matter of indifference which form of expression we use.

The former abbreviation, viz.  $\frac{\text{circumference}}{\text{diameter}} = \frac{22}{7}$ , may be translated thus:—‘The ratio of the length of the circumference to that of the diameter of a circle is equal to the ratio of 22 to 7.’

The latter abbreviation may be read: ‘The circumference of a circle is 3.1416 times its diameter.’

**Special instruments for the accurate measurement of length.**

In the foregoing measurements with a scale, it has been possible to obtain a result quite accurate to 1 mm., but only approximately accurate to .1 mm. Where the length to be measured is very short, e.g. the diameter of a wire or



tube, it is necessary to be able to ensure perfect accuracy to  $\cdot 1$  mm. or  $\cdot 01$  mm.

This may be done by attaching a vernier to the scale, or by means of a device called a screw gauge, which is described later.

**The vernier**<sup>1</sup>. The principle involved in this device will be best seen by referring to Figs. 1 A and 1 B.

In both figures *S* represents the fixed scale, having a stop *C* at the zero end, and *V* is the vernier or movable scale.

Suppose that *S* is graduated in centimetres, and it is required to measure accurately to  $\cdot 1$  cm. An actual length of 9 cm. on *S* is divided on *V* into ten equal parts (Fig. 1 A).

$$\begin{aligned} 10 \text{ divisions on } V &= 9 \text{ cm.} \\ \therefore 1 \text{ div. } V &= \frac{9}{10} \text{ cm.} \\ &= \cdot 9 \text{ cm.} \end{aligned}$$

Hence the distance between  $V_1$  and  $S_1$  (Fig. 1 A) is  $(1 - \cdot 9)$  cm. =  $\cdot 1$  cm., between  $V_2$  and  $S_2 = \cdot 2$  cm., and between  $V_6$  and  $S_6 = \cdot 6$  cm.

The object (*X*) to be measured is placed as shown in Fig. 1 B. Obviously its length is greater than 3 cm., but less than 4 cm.

<sup>1</sup> For the sake of clearness a centimetre scale has been taken, and the vernier attached reads to  $\cdot 1$  cm.

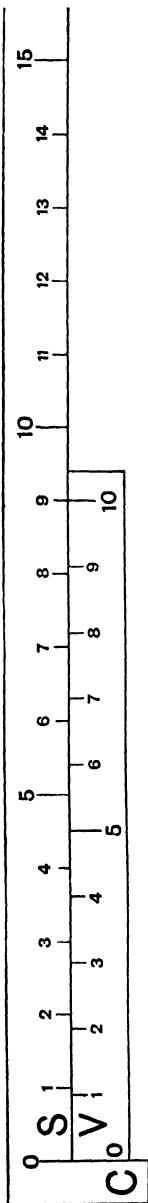

FIG. 1 A.

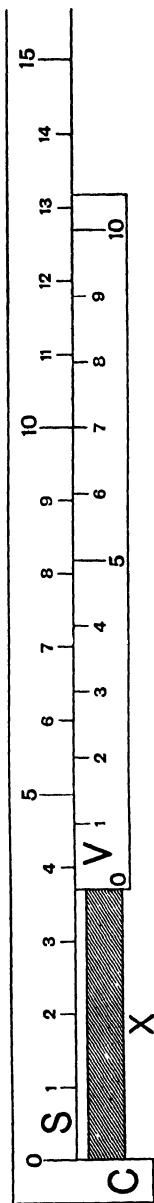

FIG. 1 B.

Notice where a mark on the vernier is exactly opposite one on the scale. In Fig. 1 B,  $V_7$  is opposite  $S_{10}$ . Working backwards from this point, it will be seen that the distance between  $V_6$  and  $S_9$  is .1 cm.,  $V_6 - S_8 = .2$  cm.,  $V_3 - S_6 = .4$  cm.,  $V_0 - S_3 = .7$  cm.

Hence  $X$  measures 3.7 cm.

The rule for using this vernier will be to find where divisions on the scale and vernier exactly coincide; the reading on the vernier at this point gives the decimal of 1 cm. required.

In case no two lines are exactly opposite, the nearest is taken, and the rest is estimated.

Notice carefully that the length of  $X$  is always the distance from  $S_0$  to  $V_0$ . The vernier enables the distance between the last division on  $S$ , and  $V_0$ , to be found accurately.

Verniers are attached to many measuring instruments, such as calipers, the barometer, &c. They are not always divided as above, but the principle is similar in all cases, and can easily be made out when the one described is understood.

For a more detailed account of the various forms of verniers see Appendix, p. 171.

#### **Exp. 5. To use sliding calipers.**

*Required:—Sliding calipers, halfpenny, sphere, glass tubes of different diameters.*

#### DIRECTIONS.

Examine the instrument, and **note—**

- (a) the fixed scale and its graduations,
- (b) the vernier and its graduations,
- (c) the two pairs of jaws—one for inside and the other for outside measurements,

(d) whether the zero of vernier is opposite zero of scale when the jaws are closed.

Measure the diameter of a halfpenny, the diameter of the sphere used in Prob. 2, p. 9, and the internal diameter of a glass tube. (Keep the tube for Exp. 9.)

### LABORATORY NOTES.

Make a careful drawing and explain how the instrument works.

Record your measurements and compare them with those previously obtained.

**The Screw gauge.** This instrument will measure accurately to .01 mm., or, if very delicate, to .001 mm. It

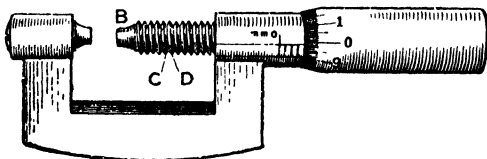

FIG. 2.

depends on the movement of a screw which has a graduated circle connected with the screw-head. The distance between two consecutive portions of the thread (*CD* in Fig. 2) is usually exactly 1 mm. When the screw-head makes exactly one revolution, the end *B* will move exactly through 1 mm. If the head only makes half a revolution, *B* moves through .5 mm.

If the circle is graduated into 100 equal parts, when the head makes  $\frac{1}{100}$  of a revolution, *B* will move through  $\frac{1}{100}$  mm., i. e. .01 mm. Hence it is possible to measure accurately to this quantity.

**Exp. 6. To use the screw gauge.**

*Required:—Screw gauge, wires of various thicknesses, halfpenny.*

## DIRECTIONS.

Examine the instrument carefully, and **note**—

- (a) the fixed scale and its graduations,
- (b) the distance the end of the screw travels for one revolution of the head,
- (c) the graduations of the movable scale,
- (d) the limit of accuracy.

Measure the thickness of some standard wires, the thickness of a halfpenny, and of a piece of writing-paper.

**Precautions.**

- (a) Before using the instrument screw it up to zero, and find if the circle marks zero. If not, allowance must be made for the difference on all readings taken, or else the instrument must be adjusted.
- (b) Be careful not to screw it up too tightly when measuring; the object should only lightly touch the jaws.

## LABORATORY NOTES.

Make a careful drawing and give a description of the gauge.  
Record your results.

---

This instrument is also known as the 'micrometer wire gauge,' or simply 'micrometer gauge.' *Micrometer* is derived from two Greek words meaning 'a measurer of small things.'

## EXAMPLES I (a).

## LENGTH.

1. How many mm. are there in (a) 1 Km., (b) 1 Dm., (c) 1 dm. ?
2. How many (a) dm., (b) cm., (c) Km. are equal to 1 Dm. ?
3. How many cm. are there in 1403.26 m.; 98.705 dm.; 1.25 Km. ?
4. Express 149.3 mm. in (a) cm., (b) dm., (c) Km.
5. Express as cm. (a) .0056 Km., (b) 50.9 mm., (c) 1.76 m. Add these together and give the result in cm. and Km.
6. Add together 6.705 Km., 8.54 m., .03 cm., and express the result in dm.
7. Convert .0012 Km. and 1555 mm. to cm. Find their difference, and express it in (a) cm., (b) Km.
8. By how many cm. do 123.4 mm. fall short of 1234 m. ?
9. A book is 1.5 cm. thick and contains 165 sheets. What is the average thickness of 1 sheet in mm. ? (Work to four places of decimals.)
10. A cyclist travels at 20 Km. per hour ; how many cm. does he cover in 1 sec. ?
11. Taking 1 metre as equal to 39.37 inches, find how many kilometres there are in (a) 1 mile, (b) 5 miles.
12. A wheel has a radius of 48 cm. Find (a) its circumference in metres, (b) how many revolutions it will make in travelling 1 kilometre.
13. A cyclometer attached to a bicycle wheel indicates that a distance of 18.5 kilometres has been covered. The wheel made 5880 revolutions. What is its diameter in cm. ? (Work to two places of decimals.)
14. Given English and metric scales, explain how you would find accurately the metric equivalent of  $\frac{1}{8}$  in.

## THE MEASUREMENT OF AREA.

An area is measured by finding how many *squares* of a certain size it contains. It might be measured by finding how many oblongs, triangles, or circles it contains, but this is never done. Since areas are always measured in squares and fractions of squares, the table denoting the relation between different units of area (p. 2) is often called the table of '*square measure*.'

**Preliminary Questions on the Measurement of Areas**<sup>1</sup>.

1. What measurements would you make in order to calculate the number of centimetre squares in a page of a book, and how could you show practically that your method was correct?

2. Could you find the area of a lozenge or diamond shaped figure in the same way, or if not, how could you do it?

3. What would be the areas of the two triangles formed by drawing one diagonal of each of the figures of Questions 1 and 2?

4. Suppose you started with a triangle, by what construction and measurements could you find its area?

5. If a circle were described on millimetre squared paper, how could you find (approximately) the number of square mm. it contained?

6. The areas of two pieces of paper *A* and *B* are described thus: '*A* is half a square inch; *B* is half an inch square.' Are the areas equal or not? Draw a diagram to illustrate your answer.

<sup>1</sup> To be done in your Fair Notebook without any help, in the way indicated on p. 3.

**Exp. 7. To measure the area of rectangles.**

*Required:—Set square and materials as in Exp. 1.*

## DIRECTIONS.

- A.* At the intersection of two thick lines on squared paper trace a line 5 cm. long and another 3 cm. long at right angles to it.  
Complete the rectangle (oblong) in pencil.  
Count the number of centimetre squares in it.
- B.* Trace out a square centimetre and count the number of millimetre squares it contains.
- C.* Trace a square having each side equal to .5 cm.  
Count the number of square millimetres in it.  
Express the area as a decimal of a square cm.
- D.* Trace a rectangle having a length of 1.4 cm. and a breadth of .6 cm.  
Express the area in sq. cm. and sq. mm.

## LABORATORY NOTES.

Record results of *A, B, C, D* thus:—

- A.* No. of sq. cm. in rectangle 5 cm. long by 3 cm. wide =  
*B.* 1 sq. cm. contains                      sq. mm., and so on.

- Questions:—*(i) How may the area of a rectangle drawn on plain paper be found without actually dividing it into squares?  
(ii) Calculate the number of sq. mm. in (a) 5 sq. cm., (b) .5 sq. cm., (c) 5.5 sq. cm., (d) .05 sq. cm.  
(iii) If a rectangle is 5 cm. long and 3 mm. wide what is its area (a) in sq. cm., (b) in sq. mm.?  
(iv) In Question (iii) how many oblongs, each 1 cm. long and 1 mm. wide, are there in the rectangle?  
(v) In Question (iii) if the numerical value of one of the answers was shown up as 15, point out the mistake and state what this number represents.

[Over

- (vi) What is the area of each triangle formed by drawing a diagonal to the rectangle in *A* ?
- (vii) How many sq. mm. are there in (a) .5 sq. cm., (b) a square having each side = .5 cm. ?

### PROBLEMS (I. 7).

1. Repeat *A*, but draw the shorter (3 cm.) line at an acute angle to the longer (5 cm.) one. Complete the parallelogram and find its area in sq. cm. Is it larger or smaller than the rectangle in *A* ?

2. Draw a rectangle as in *A*, and then from each end of the base draw parallel lines at an acute angle to meet the upper long line of the rectangle (produced in one case). Compare the areas of the two figures.

3. Devise a construction for finding the area (*a*) of any parallelogram, (*b*) any triangle.

4. Draw any irregular figure bounded by 7 or more unequal straight lines and show how to find its area.

### Exp. 8. To measure the area of a circle.

#### DIRECTIONS.

- A. Describe a circle of 20 mm. radius on squared paper. Count the numbers of millimetre squares (*a*) which are entirely within the circumference, (*b*) which are cut by it. Divide the latter by 2, and add to the former. This gives the area in sq. mm., approximately.
- B. Trace out a square on a radius of the circle, and find its area in sq. mm. Divide the area of the circle (as found in *A*) by the area of this square, recording the quotient.
- C. Measure (or calculate) the length of the circumference in mm. Draw a rectangle on the squared paper, having one side equal to half the circumference, and the other equal to the radius in mm.



Count up the mm. squares, and compare the result with that of  $A$ .

Divide the length of the long side by that of the short side, and record the quotient; compare it with that obtained in  $B$ .

### LABORATORY NOTES.

Record your results thus:—

$$\begin{array}{rcl}
 A. \text{ No. of whole mm. squares in circle} & = & \\
 \text{No. of parts of ,, ,, ,,} & \div 2 = & \text{---} \\
 \text{Total No. ,, ,, ,,} & = & \text{---}
 \end{array}$$

$$\begin{array}{rcl}
 B. \text{ No. of mm. squares in the square on} & & \\
 \text{the radius . . . . .} & = & \\
 \frac{\text{Area of circle}}{\text{Area of square on radius}} & = & \text{---} =
 \end{array}$$

$$\begin{array}{rcl}
 C. \text{ Area of rectangle formed by radius of} & & \\
 \text{circle and } \frac{1}{2} \text{ circumf.} & = & \text{sq. mm.}
 \end{array}$$

- Questions*:—(i) Do you recognize the quotient obtained in  $B$ ?
- (ii) Denoting the area of square on radius by  $r^2$ , express the area of a circle in terms of  $r$  and the quotient.
- (iii) Is the area found in  $C$  approximately equal to that of  $A$ ?
- (iv) In order to calculate the area of a circle it is only necessary to make a measurement of a length. What is the length, and how do you proceed with the calculation?

### PROBLEMS (I. 8).

1. Compare the areas of circles having radii of 1 cm., 2 cm., and 3 cm.
2. Describe a circle having an area approximately equal to 50.2 sq. cm. Test your result by counting the cm. squares.
3. Find the areas of a penny and halfpenny by the method you think will give the most accurate result.
4. Calculate the area of the surface of a cylinder by finding (a) the area of the circular end, (b) the circumference of this circle, (c) the length of the cylinder.

**Exp. 9. To find the area of cross-section of a narrow tube, using a wedge.**

*Required:—Various narrow glass tubes, and other materials of Exp. 1.*

### DIRECTIONS.

A. Make a wedge as follows:—On a piece of squared paper draw a line  $AB$  10 cm. long, number the cm. divisions from  $A$ . At  $B$  draw  $BC$  2 cm. long at right angles to  $AB$ . Complete the triangle, and from each cm. division on the base draw a line parallel to  $BC$  to meet  $AC$ . Cut out the triangle very carefully—especially near the acute angle.

B. To find the radius of the circle of cross-section of the tube used in Exp. 5.

Fit this wedge into the tube, keeping  $AB$  close to the glass, and being careful that the paper does not bend.

Read off the length of  $AB$  now in the tube, estimating to .01 cm.

This number expresses the radius of the circle in *mm*.

### LABORATORY NOTES.

Calculate the radius of the circle of cross-section as follows:—

Suppose the reading on  $AB$  is 1.85 cm.

Now the perp. at 1st cm. div. on  $AB = \frac{BC}{10} = .2$  cm.

So also    ,,   2nd ,,    ,,        =  $BC \times \frac{2}{10} = .4$  cm.

$\therefore$  the perp. at 1.85 cm. div. on  $AB = 2 \times \frac{1.85}{10} = .370$  cm.

$\therefore$  radius of circle =  $\frac{.37}{2}$  cm. = .185 cm. = 1.85 mm.

Hence the original reading on  $AB$  in cm. gives the radius in mm.

Calculate the area (using  $\pi$ ) in sq. mm. and also express it in sq. cm.

Compare the measurement of the internal diameter of tube with that in Exp. 5.

### EXAMPLES I (b).

#### AREA.

1. How many sq. cm. are there in (a) 1 sq. m., (b) 1 sq. Km., (c) 1 sq. dm.?

2. Express 1436.92 sq. m. as (a) sq. cm., (b) sq. Km., (c) sq. Hm.

3. How many sq. cm. are there in a square of 3 metre side?

4. Add together .5 sq. m., 62 sq. dm., 7.8 sq. cm., and express the result in (a) sq. cm., (b) sq. m.

5. A rectangle is 2.4 m. long and .15 m. wide. Find its area in (a) sq. m., (b) sq. cm.

6. Find the area in sq. cm. of a sheet of paper measuring .305 m. long and .096 m. wide.

7. A rectangular box lid has an area of 65 sq. dm. and a length of 10 dm. Find its width in dm.

8. An oblong field contains .061 sq. Km., and is .8 Km. long. Find its width in metres.

9. By how many sq. m. do 125 sq. dm. fall short of 6.501 sq. Dm.?

10. If 1 inch = 2.5 cm., find how many sq. cm. there are in 1 sq. in.

11. The radii of two circles measure 3 cm. and 1.5 cm. respectively. Find their areas in sq. cm.

12. A circle has a diameter of 12 mm. Find the diameter of another circle having twice the area of the first.

13. A circle has an area of 28.2744 sq. cm. Find the length of its diameter in cm.

## MEASUREMENT OF VOLUME.

The measurement of the volume—the space occupied by any object—consists in finding how many cubes of a certain size would fill this space. The method best adapted for a particular solid depends on whether it is regular or irregular in shape, and whether it is in one piece or in powder.

The volumes of liquids and gases are usually measured in graduated vessels, since they have no definite shape of their own.

**Preliminary Questions on Volume.**

How would you measure the volume in cubic centimetres of:—

1. a brick,
2. a cylinder, such as an uncut lead pencil,
3. a quantity of powdered brick,
4. an irregularly-shaped solid, such as a pebble,
5. a given quantity of water,
6. the air contained in a test-tube?

**Exp. 10. To measure the volume of some regular solids.**

*Required:—Rectangular block<sup>1</sup>, metal cylinder, right triangular prism, wooden blocks, scale, sliding calipers.*

## DIRECTIONS.

A. Measure the length and breadth of a rectangular block in centimetres, estimating to .01 cm.

Make three measurements of each dimension, and find the mean of each.

Calculate the number of cm. squares on the large face of the block. [This shows how many centimetre cubes, in one layer, would stand on the face.]

<sup>1</sup> The block and cylinder should be marked for future use.

**B.** Measure the thickness three times, and take the mean. [This number shows how many layers of centimetre cubes are required to occupy the same space as the block.]

Multiply the number of cm. cubes in 1 layer ( $x$ ) by the number of layers ( $y$ ). [This is the number of cm. cubes which would occupy the same volume as the block.]

### LABORATORY NOTES.

Record your results thus:—

A. Length of block—1st measurement	=	cm.
2nd       ,,	=	cm.
3rd       ,,	=	cm.
		cm.
Mean length	=	cm.

and so for breadth and thickness.

No. of cm. cubes which would stand on large face =

**B.** No. of layers =

Total number of cm. cubes in block =  $x \times y$ .

Express the volume ( $a$ ) in litres, ( $b$ ) in cubic millimetres.

**Questions:**—(i) If the breadth and thickness had been found in  $A$ , and the area of the *end* of the block calculated, how would you proceed to find the volume?

(ii) If you were given the volume in c.c. and the thickness in cm., how would you calculate the area of the large face?

(iii) Given the volume in c.c. and the area of the large face in sq. cm., how would you calculate the thickness?

(iv) Given the length in dm., breadth in cm., and thickness in mm., how would you calculate the volume in c.c.?

### PROBLEMS (I. 10).

1. Find the volume of a metal cylinder by measuring its length and the diameter of the circular end.

Calculate the area of this circle (using  $\pi$ ) and then the volume in c.c., using the *mean* results of your measurements.

[This cylinder should be marked in some way; it will be required for Exp. 12.]

2. Devise and carry out a method of finding the volume of a right triangular prism, or of any other regular solid supplied.

## SPECIAL INSTRUMENTS FOR MEASURING VOLUMES.

The volumes of an irregular solid lump, very small regular solids, powders, and liquids are measured best by the use of one of the vessels mentioned below. As these will frequently be used in later work, it is important that the methods of using them accurately should be thoroughly learnt.

**Exp. 11. To use a measuring jar.**

*Required:—100 c.c. or 200 c.c. measuring jar, cardboard, black paper, gum.*

## DIRECTIONS.

**A. Examine a measuring jar, and note:—**

- (a) the unit of volume on which the graduations are based;
- (b) the volume indicated between two successive numbers on the scale;
- (c) the volume between two consecutive lines on the scale;

**B. Half fill it with water, and carefully observe the surface of the liquid.**

**Note** whether the surface is—

- (a) straight or curved;
- (b) one definite line or not.

Read off the volume of water from the scale, having the eye—

- (c) above, (d) below, (e) on the water-level.

Record each reading.

Hold the jar in your hand and read the volume again, keeping the eye level with the water.

**Note** the reading, and compare with (e).

- C. Cut out a small rectangle of cardboard about 8 cm.  $\times$  4 cm. Paste a rectangular piece of black paper (8 cm.  $\times$  2 cm.) on to it, so as to cover half the card. Place it behind the measuring jar so that the lower edge of the black paper is about 2 mm. below the level of the water.



FIG. 3.

**Note** whether this makes the surface of the liquid easier to see.

Take another reading and compare it with (e).

### LABORATORY NOTES.

1. Diagram of measuring jar<sup>1</sup>, showing features noted in A.
2. Diagram to show appearance of surface of water when seen against the card (e).

- Questions:**—(i) Which position of the eye in reading the graduations do you think is best, and why?
- (ii) Why should the jar not be held in the hand while reading the level?
- (iii) If the jar holds exactly 100 c.c. of liquid, on emptying it into another vessel would 100 c.c. be transferred or not? Give reasons.
- (iv) What single measurement of length is necessary in order to calculate the area of the cross-section of the jar? [Make the measurement, and find the required area.]

<sup>1</sup> In your Fair Notes a description should also be given.

**Notes on the use of measuring vessels.**

The observations of the surface of the water in Exp. 11 will have shown that it is not flat, as you may have expected, but curved. Further, when you placed the card behind the jar you will have noticed two curves, one below the other. Such a curved surface is called a **meniscus** (crescent). When the liquid wets the vessel, as water does, the meniscus is concave (Fig. 4); but with those which do not wet

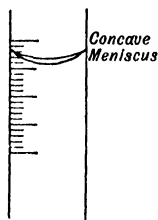

FIG. 4.

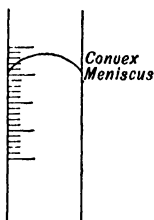

FIG. 5.

the vessel, e. g. mercury, the meniscus is convex (Fig. 5).

With a concave meniscus the position of the lowest point of the curve against the scale must be taken as the reading. With a convex meniscus the top of the curve is taken, as is done when reading a barometer.

Exp. 11 will also have shown that the position of the eye makes a considerable difference in the reading. The

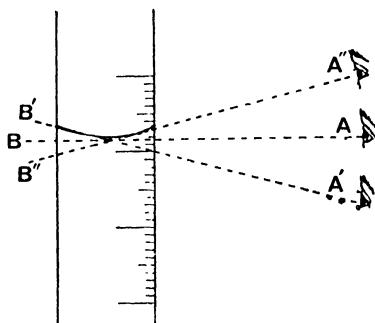

FIG. 6.

true reading is only obtained by having the line of sight perpendicular to the plane of the scale, as shown in Fig. 6.

Any error caused by the wrong position of the eye is called the **error of parallax**. It is liable to be made in reading any scale.

**Graduations on measuring vessels.** The scale etched on the glass of measuring vessels is arranged to show either (a) the volume of the liquid the vessel *holds*, or (b) the volume it will *deliver* on pouring out the liquid into another vessel.



A measuring jar may be graduated in either way, or in both ways; for accurate work it is important to know which method has been used.

The graduations themselves are liable to be slightly inaccurate, so that for very exact work they have to be carefully tested beforehand, and a table of corrections made, if necessary.

**Exp. 12. To find the volume of a metal cylinder, using a measuring jar.**

*Required:—Metal cylinder used in Exp. 10, measuring jar (200 c.c.), narrow glass tube 30 cm. long.*

#### DIRECTIONS.

Fill the jar with water to a given mark, say 100 c.c., as follows:—

Place the jar on the bench, and pour in a little more water than is required.

Extract the excess of water by means of the glass tube until the 100 c.c. mark is a tangent to the lowest curve of the meniscus.

Slope the jar, and carefully slide the metal cylinder into the water.

Read the new level, using the card and avoiding errors of parallax.

#### LABORATORY NOTES.

Describe the method of filling the jar up to a given mark.

Record of readings and deduction of the volume of the cylinder. Compare result with that in Exp. 10, Prob. 1.

*Questions:—*(i) How many scale readings were made in finding the volume of the cylinder (*a*) in Exp. 10, Prob. 1, (*b*) in Exp. 12? Assuming the scales to be equally accurate, which method is most likely to give the best result, and why?

(ii) Knowing the volume and length of the metal cylinder, calculate the area of its circular end.

## PROBLEMS (I. 12).

*Required:—Strip of lead, small piece of wood, sand.*

1. Using the method of Exp. 12, find the volume of a *strip of lead*.

2. Devise a means of adapting this method for finding the volume of a *piece of wood*; then carry it out, if approved.

3. Find the volume of the *sand* supplied, being careful to get rid of air bubbles, before taking the second reading.

**Exp. 13. To use a burette.**

*Required:—Burette, clamp and stand, grease, india-rubber band, small porcelain dish.*

## DIRECTIONS.

A. Examine a burette, and **note**—

- (a) the unit of volume used as the basis for graduation,
- (b) from which end the graduations begin,
- (c) the volume indicated between two successive numbers on the scale,
- (d) the volume between two consecutive lines on the scale,
- (e) the tap and nozzle.

Measure the distance in cm. between the divisions numbered 1 and 2. Calculate the area of cross-section of the burette in sq. cm.

N.B.—*A burette is graduated to deliver the volume indicated by the scale.*

B. Find whether the tap works smoothly—if not, grease it slightly, but prevent the grease from getting into the boring.

Fasten a rubber band on the tap handle, pass it under the nozzle and over the other end of the barrel of the tap. This prevents the tap from slipping horizontally

Clamp the burette on a retort-stand, with the scale to the front, and the tap on the right-hand side.

Adjust it to a vertical position by a plumb line, i. e. a piece of thread fastened to a small piece of lead.

Place a small funnel at the top, and pour in water until the level is above the zero mark.

Run out a little water into a dish, so as to fill the taping and nozzle.

Adjust the level to the 40 c.c. mark, using a black paper card, and avoiding errors of parallax.

*C.* Allow the water to run out, drop by drop, until 30 drops have escaped.

Read the level again correct to .1 c.c., and estimate to .01.

Find the volume of water thus run out, by subtracting the first reading from the second.

Calculate (*a*) the volume of 1 drop in c.c. ;

(*b*) the number of drops in 1 c.c.

### LABORATORY NOTES.

Diagram of burette and tap showing the features noted in *A*.

Enlarged diagram of appearance of meniscus as it is seen with the card behind it.

Readings, &c. —

Distance between divs. 1 and 2	. =	cm.
Area of cross-section	. . . =	sq. cm.
2nd reading, after escape of 30 drops	=	c.c.
1st „ before „ „ „	=	c.c.
Vol. of 30 drops	. . . =	c.c.
∴ vol. of one drop	=	c.c.
No. of drops in 1 c.c.	=	

[In the Fair Notebook insert a full description of *B* and *C*.]

*Questions*:—(i) Why is it always necessary to run a little liquid out of the burette before noting the first reading on the scale?

- (ii) Why is it necessary to have the burette vertical?
- (iii) Will a slightly wrong position of the eye make as great an error in reading a burette as in reading a measuring jar? Give reasons.
- (iv) Which of the two do you consider the more accurate—a burette or a measuring jar? Give reasons.

### PROBLEMS (I. 13).

*Required:—Shot, measuring jar, small flask, standard flask, burette.*

1. Using a burette, find (a) the volume of 30 lead pellets, (b) average volume of 1 pellet.

2. Test the accuracy of the graduations on the measuring jar (assuming those of the burette to be correct) by running in successive volumes of 20 c.c. of water from the burette to the jar. Read the volume of water in the jar each time.

3. Find the volume of a small flask up to a rubber band round the neck.

Adjust the water-level in the burette to zero and run it into the flask, but not farther than the lowest mark on the scale. Refill the burette, and repeat until the flask is filled with water up to the mark.

Such a vessel is called a *Standard Flask*. It is graduated to hold a certain volume.

4. Test the accuracy of the standard flask provided, by means of a burette or measuring jar (graduated for delivery).

**Ex. 14. To use a pipette.**

*Required:—A pipette, two small dishes.*

**DIRECTIONS.**

**A.** Examine a pipette, noting its shape, the scratch on the stem, and the capacity marked on the bulb.

N.B.—The volume indicated on the bulb is what the pipette will *deliver*.

It is used to transfer a known volume of liquid from one vessel to another.

**B.** Suck up water from the dish into the pipette until its level is above the scratch on the stem.

Put the finger quickly on the top without letting the water-level sink below the mark.

Hold the pipette over the dish with the scratch level with the eye.

Relax the pressure of the finger until the lower edge of the meniscus is just level with the scratch. (Practise this until it can be done easily.)

Now hold the end of the pipette over a dry dish and remove the finger, so as to allow the water to run out.

Hold the pipette over the dish for three or four seconds longer, and touch the surface of the water with the end of the pipette, thus causing a little more water to run out, but do not blow out the residual water.

The dish now contains 10 c.c. of water.

**LABORATORY NOTES.**

Diagram of pipette showing meniscus.

(For Fair Notes a full description of *B* in your own words is to be given.)

**Questions:—**(i) Why is the temperature marked on pipettes, standard flasks, &c., as well as the volume?

(ii) Make a list of the vessels you have used which (a) *hold* a given volume, (b) *deliver* a given volume.

## EXAMPLES I (c).

## VOLUME.

1. How many c.c. are there in (a) a litre, (b) a cubic metre?
2. Express 1256 c.c. as (a) litres, (b) c.mm., (c) c.m.
3. Add together 3.67 litres, .05 c.m., 257 c.c., giving the total in litres.
4. What difference in c.mm. is there between .012 litre and 11.5 c.c.?
5. A box measures 35 cm. long, 15 cm. wide, and 7 cm. deep. Find its volume in (a) c.c., (b) litres.
6. The area of the floor of a room is 35.6 sq. m., and the height of the room is 3.3 m. Find its volume in cubic metres.
7. A box has a volume of 25 litres and the area of the lid is 8.5 sq. dm. Find its depth in cm.
8. Find the volume of a cylinder in c.c., its length being 7.6 cm., and the diameter 2.5 cm.
9. A measuring jar holds 200 c.c. of water when filled to a point 30 cm. above its base. Find the area of the cross-section in sq. cm.
10. A tube holds .1 c.c. of water and is 1 cm. long. What is the area of its cross-section in sq. mm.?
11. If 1 in. = 25 mm., how many c.c. are there in 1 cubic inch, and how many litres in 1 cubic foot?
12. What length of wire of 1 sq. mm. cross-section can be drawn from 1 litre of the metal? Give the answer in metres.

## CHAPTER II

### CONSTRUCTION OF SIMPLE APPARATUS

#### Laboratory gas-burners.

*Required:—(Exp. 1 and 2) Bunsen and bat's-wing burners, asbestos fibre (or narrow strip of asbestos card), glass tube.*

#### Exp. 1. Examination of a Bunsen burner.

##### DIRECTIONS.

A. Notice the holes for admission of air near the base of the tube.

Unscrew the tube, and notice the holes for the issue of the coal-gas.

Turn on the tap, and light the gas.

**Note** the shape and colour of the flame.

Turn off the tap, replace the tube, closing the holes at the base, and relight.

**Note** the different shape of the flame.

Also notice whether the flame is equally luminous all over or not, e. g. (*a*) just above the tube, (*b*) at the edges, (*c*) middle, (*d*) top.

Hold a piece of glass tube in the flame. **Note** the deposit.

Open the holes at the base and hold the tube just used across the middle of the non-luminous or blue flame, and observe what happens to the black deposit.

*B.* Hold a thin piece of asbestos fibre (or a narrow strip of asbestos card) horizontally across the non-luminous flame, starting at the top of the tube.

**Note** where it gets hot first.

Raise it to higher parts of the flame.

**Note** the results in each case.

*C.* Repeat the experiment with asbestos in the luminous flame.

### LABORATORY NOTES.

Observations *A*, *B*, and *C*.

Diagram to show structure of (*a*) the burner, (*b*) the non-luminous flame.

*Questions*:—(i) Which flame is longest, the luminous or the non-luminous?

(ii) Which are the hottest parts of the luminous flame?

(iii) Which kind of flame is hottest?

(If in doubt, try which will melt a thin glass tube quickest.)

(iv) Which flame would you use to heat a glass tube, and why?

### **Exp. 2. Examination of a bat's-wing burner.**

Notice the holes from which the gas issues, then light the burner.

**Note** the colour and shape of the flame.

Test for the hot and cool parts with asbestos.

Draw a diagram showing the luminous and non-luminous parts of the flame.

*Questions*:—(i) In what way does the shape of the flame differ from that of a Bunsen burner?

(ii) In what ways is it less suitable for heating a flask of water than an ordinary Bunsen flame?



**Simple glass working.**

*Required for Exps. 3-10:—Triangular and rat-tail files, glass tubes of various widths, glass rod, bat's-wing luminous burner.*

**Exp. 3. To divide narrow glass tubes.**

Lay the tube on the bench, make a scratch with a triangular file at the point at which it is desired to cut it.

Hold the tube in both hands, placing the thumbs on the opposite side of the tube from the scratch.

Press the thumbs against the tube, and pull the ends of the tube towards you.

**Exp. 4. To break off a jagged end.**

Make a scratch as before, and place the tube, with the scratch uppermost, on the edge of a file lying on the bench. (The edge of the file must be vertically below the scratch.)

Hold the tube firmly in position, and knock off the jagged end with a key or other heavy object.

Draw a diagram to illustrate the operation.

**Exp. 5. To divide wide glass tubes.**

*A. If the tube has thin walls, make a sharp scratch as before; now take a piece of glass rod and heat the end in the Bunsen flame. When it is soft, flatten it by pressing first one side and then the other on the foot of the burner. Heat the flattened end till red hot, press the edge along the scratch so as to*

[Over

start a crack which can be made to follow round the tube.

Practise this until you can do it well.

*B. If the tube has thick walls, make a scratch completely round it.*

If it cannot be broken by gentle pressure of the hands, use a hot glass rod as before.

**Exp. 6. To round the edges of a glass tube.**

Before glass tubes are used for any purpose, the sharp edges must be rounded by being heated near the top of a *Bunsen flame*.

*A.* Hold the tube in the flame with the end directed downwards. Keep the tube revolving on its axis until the edges are red hot.

**Precaution** :—Avoid heating the tube too long. Find out the reason for the precaution, by keeping another tube longer in the flame.

**Note** the difference in the width of the two tubes at their ends.

*B.* Cut off two pieces of glass rod 2 dm. long, round the edges, and keep for subsequent use as ‘stirring rods.’

**Exp. 7. To seal a glass tube.**

Hold a piece of fairly wide (1 cm.) tube in both hands across, and near the top of a *Bunsen flame*.

Rotate it constantly until it is quite soft.

Take it out of the flame, and while still rotating it, pull gently at the two ends.

Allow it to cool, and cut the tube at the narrow part.

Close up the end by melting, heating it strongly.

Take it out of the flame, and blow gently down the tube so as to press out the end to the same width as the rest.

**Exp. 8. To draw out a narrow tube from a wide one.**

A. Hold the tube across the *Bunsen flame* near the top.

Keep it rotating until it is red hot, and quite soft.

Then take it out of the flame and draw the ends apart carefully till the tube is of the required diameter.

B. Make ten narrow (1 mm.) and thin-walled tubes, 8 cm. long, from a piece of No. 3 tubing.

Seal one end, and keep for future use in a dry test-tube.

[Some of these tubes will be required for finding melting-points, later on.]

N.B.—A tube of very narrow bore is called a '*capillary tube*,' from the Latin *capilla*, a hair.

**Exp. 9. To bend glass tubes.**

In order to bend a tube, so that the bore may be of uniform thickness throughout, it must be evenly heated all round.

## DIRECTIONS.

A. Hold a piece of narrow tubing horizontally with both hands in a Bunsen flame.

Rotate it until soft.

Take it out of the flame and bend it at right angles.

**Note** whether the bore of the tube is altered at the bend.

B. Repeat A, bending the tube in the flame.

**Note** whether the result is better or worse.

C. Repeat A and B, using a luminous bat's-wing burner with a flame about 5 cm. wide.

Hold the tube horizontally *along* the flame, not across it.

When it is quite cold wipe off the soot.

D. Having found which flame is best, use it to make a right-angled bend, with one limb 8 cm. long, and the other 18 cm. Use a straight tube not less than 30 cm. long. Make the side last in the flame form the concave part of the bend. Round the edges, and keep for future use.

## LABORATORY NOTES.

Diagrams of the bends A, B, C.

**Questions** :—(i) Which is the best flame for bending a glass tube?

(ii) Explain what causes it to be the best?

(iii) Why is it so important to rotate the tube before bending it?

(iv) Draw an enlarged diagram of each of the three bent tubes.

(v) Is it best to bend the tube inside, or outside the flame? Explain why.

(vi) What is the effect on the bend of the glass getting too soft? (If in doubt, try it.)

**Exp. 10. To bend a tube at a given angle.**

A. Draw two lines  $AC$  and  $BC$  on paper, meeting at  $C$  at an angle of  $35^\circ$ .

Rotate a tube (3 dm. long) in a luminous *bat's-wing* flame till soft, so that the heated part is about 1 dm. from one end.

Take it out of the flame, and hold it so that the middle of the hot part is just over  $C$ .

Bend the tube until the two limbs coincide with  $CA$  and  $CB$ .

Cut off the limbs down to 8 cm. and 18 cm. respectively. Fig. 7 represents the properly bent tube.

B. Bend two tubes at an angle of  $120^\circ$ , so that the limbs of the first are 10 cm. long, and of the second 32 cm. and 2 cm. respectively. Use the same method as in A.

The bent tube should appear as in Fig. 8.

C. Bend a tube (40 cm. long) twice at right angles having the ends of the tube pointing the same way.

The lengths of limbs are shown in Fig. 9.

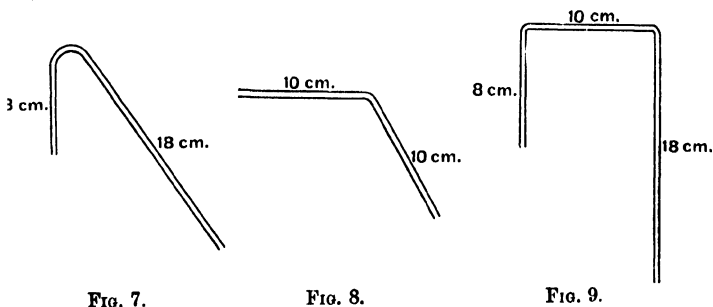

FIG. 7.

FIG. 8.

FIG. 9.

**Precaution:**—Be careful that the limbs are in the same plane, so that the bent tube will lie flat on the bench.

Repeat the experiments, if not successful at first.

Round the edges, and keep these tubes for future use.

**Exp. 11. To bore a cork.**

*Required:—Corks of various sizes, set of cork-borers, rat-tailed file.*

The object of boring a cork is usually to enable a glass tube to be pushed through it, so that it fits perfectly tightly.

You may take a cork and try to bore a hole with a borer in your own way. If unsuccessful, try again, carrying out the following *directions*:—

(a) Take a glass tube which is to pass through the cork, and press the end on the narrower end of the cork, so as to form a circle on the cork.

(b) Choose a borer slightly narrower than the glass tube. (Try the borers by placing them on the circle impressed on the cork.)

(c) See that the borer is sharp. (If not, gently file the edges until it is.)

(d) Place a cross piece through the hole at the top of the borer so as to form a handle.

(e) Hold the cork with its broader end in your left hand and bore the hole by turning the borer like a corkscrew, half a turn at a time.

Moisten the glass tube (the edge being rounded) and carefully push it through the cork.

Unless it fits tightly another cork must be bored.

If it is too tight to pass through gently, file the cork *evenly* with a rat-tailed file.

N.B.—In choosing corks for flasks be careful to see that they will fit tightly. A cork which is rather too large may be made to fit by gently rolling it under the foot, or by squeezing it in a cork-presser.

**Exp. 12. To fit up a flask with an exit tube.**

*Required:*—100 c.c. flask, cork, borer, narrow glass tube (No. 3 size).

## DIRECTIONS.

Choose a cork which fits the flask. Bore a hole of the right size for the narrow exit tube.

Cut off a length of about 30 cm., round the edges, and push it through the cork till about 1 cm. protrudes.

Fit the cork into the flask.

Now test the apparatus to find whether it is air-tight, by blowing down the tube. If it is tight no air can be blown through; if not, either the cork does not fit the neck of the flask or the hole in the cork is too large. In the latter case, take another cork and try again.

N.B.—It is most important to test apparatus in this way, and to learn to fit and bore corks so that they are air-tight. Much time will be wasted in future if you do not learn to do this properly.

[Keep the apparatus for Exp. 2, Chap. III.]

**Exp. 13. To dry a wet flask quickly.**

*Required:*—100 c.c. flask, glass tube, foot-bellows.

## DIRECTIONS.

Wash out a flask with water and dry it on the outside; pass a glass tube into the flask, so that a blast of air can be blown through it, either from the mouth or by attaching it to the rubber tubing from the foot-bellows.

Hold the flask mouth downwards on the tube at some distance above a small Bunsen flame; rotate the flask slowly, and blow a stream of air into it until it is quite dry.

Any moisture which remains in the neck of the flask may be removed by means of blotting-paper.

**Hints on fitting up apparatus.**

1. Before bending tubes be sure that you know the angle and the length of the limbs required. Always make the latter a little longer than is necessary and cut them down.

2. Bore corks a little narrower, if anything, than is required, and widen the hole with a round file if necessary.

3. If a tube or thermometer has to be pushed through a cork, moisten it with water and push gently with a corkscrew motion. If too much pressure is applied it is liable to break and cut your hand.

4. See that the apparatus is air-tight and clean before beginning to use it.

5. When the apparatus is to be fixed on a stand, see that the whole is **neat** and **convenient for use**, and in a position where it is not likely to be knocked over.

6. Never heat flasks over an open flame, but place wire gauze or some form of heat distributor underneath.

7. Remember that flasks, beakers, &c., are made of thin glass, and will easily break unless care is taken.

8. A rubber-tube connexion may be tightened by turning back the ends of the rubber over itself.



## QUESTIONS ON CHAP. II.

1. Explain how you divide (*a*) narrow, and (*b*) wide glass tubes.
2. How do you round the edges of a glass tube? What precautions are to be taken, and why? What kind of flame is used? What is the object of rounding the edges?
3. In sealing off a glass tube, why is it important not to pull the ends very far apart after heating? Describe the whole process of sealing.
4. Make a diagram of a Bunsen burner, and describe it fully.
5. Make a sketch of a bat's-wing burner, and explain why such a burner with a luminous flame is used for bending tubes. Draw a bend made with (*a*) a bat's-wing burner, (*b*) a Bunsen burner.
6. Why is it necessary to rotate a tube, when it is being heated previous to bending? Why is the tube bent outside the flame and not in it?
7. What is a capillary tube? and how is it made?
8. Explain fully how you bore a hole through a cork so as to be able to pass through it a glass tube which shall fit tightly.
9. Give an account of a way of drying a wet flask rapidly.

## CHAPTER III

### SIMPLE EFFECTS OF HEAT. THE THERMOMETER

#### **Preliminary Questions on Heat<sup>1</sup>.**

1. A piece of metal and a piece of wood are lying together in the same room. Which would feel coldest to the hand? Is one really colder than the other? Give reasons for your answer.

2. Why are two pieces of ivory often inserted between a teapot and its handle?

3. Explain how it is that a wire screen placed before a fire causes the heat to feel less intense to the hand.

4. Does heat alter the size of bodies? Give examples drawn from your own experience of its effect (if any) on a solid, a liquid, and a gas.

5. Why do thick vessels crack more easily than thin ones, when they are suddenly heated?

6. When heat is applied to a large piece of melting ice, does the ice get hot? Why does it take so long to melt?

7. Do you think that boiling water gets hotter, the longer it is heated? Give reasons for your answer, and state what becomes of the water.

8. Do other liquids such as methylated spirit and turpentine become as hot when they boil as boiling water?

9. Do all solids require to be heated to the same degree before they melt? Illustrate your answer by several examples.

10. Name and describe the instrument commonly used for testing the hotness or coldness of things.

<sup>1</sup> Answer the questions in your Fair Notebook from your general knowledge as explained on p. 3.

**Exp. 1. On the conducting power of solids for heat.**

*Required:—Rods of glass, copper and iron of equal length and thickness, wire gauze.*

## DIRECTIONS.

A. Hold the ends of a glass and of a copper rod—one in each hand—and place the other ends close together in a Bunsen flame.

**Note** which feels hottest after a short time.

Cool the copper rod, and try the experiment again, using copper and iron.

**Note** which of the two seems to conduct heat best.

B. Hold a flat piece of wire gauze with tongs, and lower it gradually over a Bunsen flame.

**Note** the effect when the gauze is about half-way between the original top of the flame and the top of the burner.

Lower the gauze right down to the burner, and observe the result.

C. Turn off the gas, and place the gauze about two inches above the burner.

Turn on the gas, and bring a lighted taper down on to the *top* of the gauze.

**Note** the position of the flame.

Withdraw the gauze sideways, and observe the result.

## LABORATORY NOTES.

Observations in *A*, *B*, and *C*.

**Questions:—**(i) Which of the three substances conducts heat best and which worst?

(ii) Explain the effect observed in *B* and *C*.

(iii) Why is wire gauze placed under glass vessels before heating them?

**Exp. 2. To find whether the volume of water alters on heating.**

*Required :—Apparatus as in Fig. 10.*

### DIRECTIONS.

Use the flask fitted up at end of Exp. 12, Chap. II, as shown in Fig. 10.

Warm some water in a water-bath or beaker large enough to hold the flask.

Fill the flask to the brim with cold water, and push in the cork carrying the tube.

Mark the level of the water in the tube at *X* with a rubber band or a piece of gummed paper.

Place the flask in the warm water, watching what happens at *X*.

**Note** whether the water-level rises or falls (*a*) at first, (*b*) afterwards.

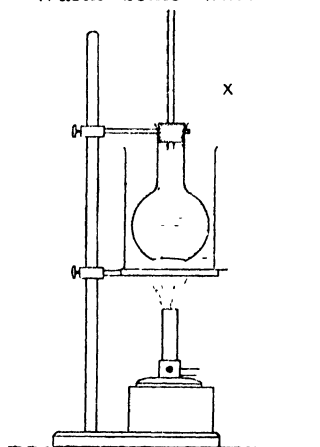

The apparatus can be used for other liquids.

### LABORATORY NOTES.

Diagram and observations.

**Questions :—**(i) Did the water rise or fall at first? Explain the cause.

(ii) Does water expand on heating?

(iii) Does glass expand on heating? Give reasons.

(iv) Why is it necessary to state the temperature (*a*) of water in defining the 'gram'; (*b*) of the metal bar in defining the 'metre'?

Advantage is taken of the expansibility of liquids in making thermometers, which are instruments for ascertaining the temperature of bodies accurately.

**Exp. 3. Examination of a thermometer.**

*Required:—A centigrade thermometer.*

## DIRECTIONS.

Examine a centigrade thermometer, holding it at the top, and **notice** :

- (a) the bulb and its contents ;
- (b) the stem, its contents, and whether it is open or closed at the top ;
- (c) the scale. *Note specially* : the lowest number ; whether the numbers increase or decrease as you look up the scale ; where the zero point is ; whether the numbers increase or decrease above zero ; where the 100 mark is ; the numbers above this.
- (d) how many marks there are between numbers 50 and 60 ;
- (e) whether the numbers are above or below the marks they denote ;
- (f) whether the thread of liquid is continuous from the bulb upwards, or whether the thread is broken and a space intervenes ;
- (g) the temperature it registers at the moment ;
- (h) the effect of holding the bulb in your hand.

**Precautions.**

(a) Before using a thermometer find whether the thread of liquid is broken or not. If it is, shake the thermometer *gently* until the thread joins up.

(b) Never put a thermometer into or above an open flame.

## LABORATORY NOTES.

Diagram of the thermometer showing the features (a), (b), (c), (d).

Give a reason for the second precaution.

**Exp. 4. To learn how a thermometer is graduated.**

*Required:—Centigrade thermometer, flask with long neck, ice, cork, water-bath (or beaker) holding warm water.*

#### DIRECTIONS.

A. Choose a flask with a long neck, and carefully introduce some pounded ice, until half full.

Stir the ice *gently* with the thermometer.

**Note** the lowest point to which the thread of mercury sinks. This is called the *lower fixed point* of the thermometer, or the melting-point of ice.

Place the flask in warm water, as shown in Fig. 11. (There must be no flame under the water-bath.)

**Note** the temperature of the water.

Stir the ice with the thermometer for a minute or two.

**Note** whether the temperature of the ice alters or not.

Repeat this until the ice has all melted, recording the temperature.

**Note** the temperature of the water in the bath again.

B. Take a cork which fits the flask, and bore two holes through it, one just wide enough for the thermometer to pass through without undue force being used, the other to take a right-angled tube.

Moisten the thermometer with water, and *gently* push the thermometer through the cork with a screwing motion. (If the hole is too narrow widen it with a round file.)

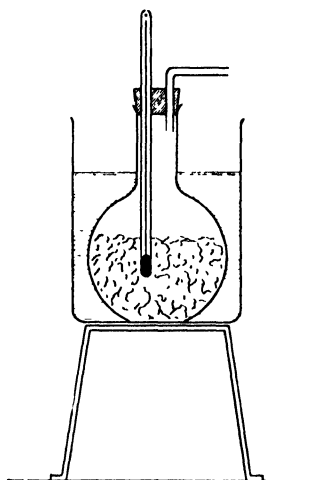

FIG. 11.

Place the cork in position so that the bulb of the thermometer is covered with water.

Wipe the flask, and heat gently on wire gauze.

Continue heating until the water boils.

**Note** the highest point which the mercury reaches.

Now raise the thermometer until the bulb is clear of the water, and surrounded only by steam.

**Note** whether the temperature is lower or higher than when the bulb was in the water.

This latter point is the *higher fixed point* of the thermometer or the boiling-point of water.

These 'fixed points' are always marked before the graduations are made.

In a centigrade thermometer, the space between the fixed points is divided into 100 equal parts, each of which is called a *degree*. The graduations are then continued above the higher and below the lower fixed point, as far as the stem extends.

### LABORATORY NOTES.

Observations *A* and *B* and diagram.

*Questions*:—(i) Did the temperature of the ice alter while melting?

(ii) Was the ice receiving heat while melting? Give a reason.

(iii) Did the warm water cool while the ice melted?

(iv) Why is a long-necked flask required for *B*?

(v) After the water starts boiling does it still receive heat? Give a reason.

(vi) Does the temperature alter during boiling?

### PROBLEM (III. 4).

Repeat Exp. 4 (*A* and *B*) with a mixture of pounded ice and salt, but do not place the flask in warm water.

**Note** the temperatures as before and compare them with those recorded for pure ice.

What effect has the salt on (a) the melting-point of ice, (b) the temperature of the boiling liquid, (c) the temperature of the steam?

## OTHER METHODS OF GRADUATING THERMOMETERS

The centigrade thermometer, which is universally used in scientific work, is so named because the space between the two fixed points is divided into 100 equal grades or degrees. There are two other thermometer scales which differ only in the number of divisions between the fixed points, viz. Fahrenheit's and Réaumur's. On Fahrenheit's scale the fixed points are marked  $32^{\circ}$  F. and  $212^{\circ}$  F.; on Réaumur's,  $0^{\circ}$  R. and  $80^{\circ}$  R.; while on the centigrade thermometer they are  $0^{\circ}$  C. and  $100^{\circ}$  C. (Fig. 12).

Thus the space between the fixed points is divided into :

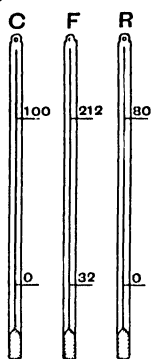

FIG 12.

100 parts on the centigrade scale.

180 " " Fahrenheit "

80 " " Réaumur "

180 divisions F. = 100 divisions C.

$\therefore 1 \text{ div. F.} = \frac{100}{180} = \frac{5}{9} \text{ div. C.}$

Similarly  $1 \text{ div. C.} = \frac{9}{5} \text{ div. F.}$

In converting Fahrenheit readings to centigrade, *first* subtract 32, and then multiply by  $\frac{5}{9}$ ; in converting centigrade to Fahrenheit, multiply by  $\frac{9}{5}$ , and *afterwards* add 32.



## LATENT HEAT.

In the last experiment it was found that the temperature of the ice remained at  $0^{\circ}$  C. until it all (or very nearly all) melted, although heat was being received from the hot water the whole time. Similarly, after the temperature of the water had risen to about  $100^{\circ}$  C., it remained stationary, although the flame was still heating the water.

This shows that the thermometer does not measure the 'quantity of heat' in a substance, but only its relative hotness or coldness, i. e. its temperature. Water at  $0^{\circ}$  C. therefore contains more heat than an equal weight of ice at  $0^{\circ}$  C. This heat, which is 'hidden' from the thermometer, is called the 'latent heat' of water (Latin *lateo*, to lie hidden). Similarly, when water is boiled the temperature remains at  $100^{\circ}$  C., and there is 'latent heat' in steam.

The fact that 1 gram of steam at  $100^{\circ}$  contains more heat than 1 gram of water at  $100^{\circ}$  could be shown by finding the weight of ice which each could melt. The steam would melt about six times as much as the water.

The fact that ice takes in heat whilst melting follows from the observation that its temperature remains the same until the whole of it has melted, but it is not easy to show that the reverse is true in the case of the change from water to ice. In order to show that heat is given out when a liquid changes to the solid state, use will be made of a substance named sodium thiosulphate, usually called 'hypo.'

**Exp. 5. To show that a liquid loses its latent heat on solidifying.**

*Required:—Finely powdered 'hypo,' small flask (2 oz.), thermometer, water-bath (or beaker).*

#### DIRECTIONS.

Warm some water in the bath, or in a beaker standing on gauze.

Half fill a small flask with 'hypo,' and place it in the warm water.

Place a thermometer in the flask, and stir the hypo gently, until it is melted.

**Note** (a) whether the temperature rises continually or stops after a time;

(b) whether the temperature alters after all the solid has melted.

After all has melted, take out the flask and allow it to stand (with the thermometer inside) until the temperature is about 20° C.

Drop a small piece of 'hypo' into the flask.

**Note** (c) the reading of the thermometer, and what happens to the contents of the flask.

#### LABORATORY NOTES.

Record of the temperature of the hypo (a) just before it all melted, (b) just before the solid fragment was dropped in, (c) final temperature.

**Questions:—**(i) Compare the temperature changes on melting (a) ice, and (b) hypo.

(ii) Does the temperature alter during melting in either case?

(iii) How do you explain the alteration in temperature of the hypo when it is suddenly made to solidify?

#### PROBLEM (III. 5).

Try a similar experiment with acetate of soda.

**Exp. 6. To find the melting-point of a solid.**

*Required:—Melting-point tubes, thermometer, rubber bands, beaker, stirrer, clamp and stands, naphthalene, spermaceti.*

## DIRECTIONS.

## A. Use spermaceti; then naphthalene.

Break up the solid into powder, and introduce a small quantity into the melting-point tube by pressing the open end of the tube into the powder and tapping the closed end on the bench.

Fasten the tube to the thermometer by a rubber band, so that the solid is opposite the bulb (Fig. 13). Clamp the thermometer with the bulb dipping into water as shown in Fig. 14.

Place a small flame under the beaker, stir constantly, and watch for the first signs of melting. Then remove the flame from beneath the beaker, and stir vigor-

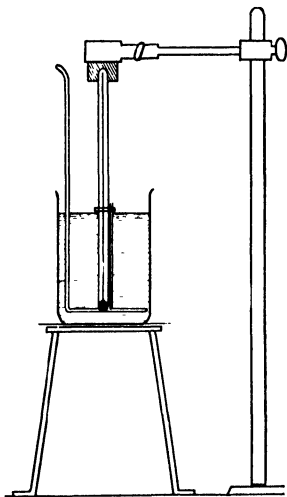

FIG. 13.

FIG. 14.

ously; note the temperature at which the solid shows the first signs of melting, and observe whether complete melting takes place at this temperature.

Do *three* experiments with each solid, and take the mean of the three results.

## B. Mix a little spermaceti with about ten times as much naphthalene, and find the melting-point of the mixture.

## LABORATORY NOTES.

Diagram and short description of method.

A record of the three results obtained for each substance.

A comparison of the melting-points of pure naphthalene and spermaceti with that of the mixture.

*Questions*:—(i) What conclusion would you draw as to the purity of a substance whose melting-point is not sharp?

(ii) What are the advantages of using a small quantity of the solid in a thin-walled narrow tube, and of having the solid close to the bulb of the thermometer?

If a substance melts at a temperature above  $100^{\circ}$  C., some liquid other than water must be used to heat it. For this purpose melted paraffin wax or olive oil may be used.

## PROBLEM (III. 6).

Find the melting-point of *sulphur*, using a bath of melted *paraffin wax*.

Submit your method for approval before proceeding.

**Exp. 7. To find the boiling-point of a liquid.**

*Required:—Wide test-tube, doubly bored cork, thermometer and exit tube, pure alcohol.*

## DIRECTIONS.

A. Arrange the apparatus as in Fig. 15, being careful not to clamp the tube too tightly.

Place a small quantity (3 cm. deep) of alcohol in the tube.

Fix the bulb of the thermometer about 4 cm. above the surface of the liquid.

Use a *small* flame and heat to boiling, and allow to boil for a few minutes.

**Note** the temperature:

- (a) at which boiling begins,
- (b) a few minutes after.

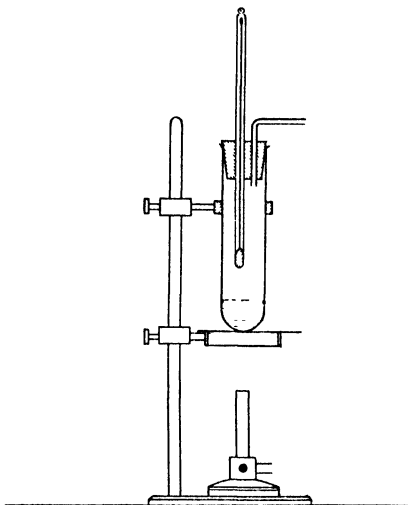

FIG. 15.

B. Allow it to cool, and then add an equal volume of water to the liquid in the tube.

Repeat the experiment.

**Note** the temperature:

- (c) at which boiling begins, (d) two or three minutes after.

## LABORATORY NOTES.

Diagram of apparatus.

Record of temperatures (a), (b), (c), and (d).

*Questions:—*(i) Does the temperature alter during the boiling of (a) pure alcohol, (b) the mixture of alcohol and water?

[Over

- (ii) How can you tell whether a given sample of alcohol is pure?
- (iii) How would you test whether (a) a given liquid, (b) a given solid, is pure or not?

### PROBLEM (III. 7).

Find the boiling-point of the *acetone* supplied.

N. B.—Acetone is very inflammable, and must be heated by immersing the tube containing it in a beaker of hot water.

### QUESTIONS ON CHAPTER III.

1. Answer the preliminary questions on heat, Nos. 1–9, p. 48.
2. Explain the object of placing wire gauze under flasks before heating them.
3. Give an account, with explanations, of the effects produced on boiling a liquid contained in a narrow test-tube.
4. How are the fixed points on a thermometer determined, and what precautions must be taken to avoid errors?
5. Explain the difference between the centigrade and Fahrenheit scales? What will be the centigrade equivalent for  $100^{\circ}\text{F.}$ ,  $0^{\circ}\text{F.}$ ,  $-32^{\circ}\text{F.}$ ?
6. Calculate the Fahrenheit reading corresponding to  $40^{\circ}\text{C.}$ ,  $212^{\circ}\text{C.}$ ,  $32^{\circ}\text{C.}$ ,  $-10^{\circ}\text{C.}$ ?
7. What is meant by the term '*latent heat*'? Devise an experiment to show that a gram of steam at  $100^{\circ}\text{C.}$  contains more heat than the same weight of boiling water.
8. How can you show that a liquid gives out heat when it solidifies?
9. Describe a method for determining the temperature at which (a) a solid melts, (b) a liquid boils.
10. Explain an easy way of testing whether (a) a given liquid, (b) a given solid, is a single substance or a mixture.

## CHAPTER IV

### THE CHEMICAL BALANCE

**Exp. 1. Examination of a box of weights.**

*Required:—Box of weights, forceps.*

#### DIRECTIONS.

A. Look carefully at the weights in the box, and see how they are arranged and marked.

**Note** that there are two kinds: the heavier ones which are generally made of brass, and the lighter ones of a white metal, usually platinum, aluminium, or German silver.

**Precaution:** The weights must never be touched with the fingers, which would cause tarnishing; always use the forceps.

B. Write down the weights of each brass piece in your notebook.

Add up the total.

Draw an oblong diagram, as in Fig. 16.

Divide the oblong into as many divisions as there are white metal weights.

In the upper row of spaces put down the values of the

Milligrams.	500	200	100	100	etc.		<i>Total</i>
Decimals of a gram.	.5	.2	.1	.1	etc.		<i>mg.</i>
							<i>gs.</i>

FIG. 16.

weights in milligrams; in the lower row give their corresponding values as decimals of a gram.

Add up both of them, and put their totals at the end.  
What is the sum of all the weights in the box?

N. B.—The white metal weights are marked by some makers in milligrams, and by others in decimals of a gram, and sometimes in all the three subdivisions of a gram. See that you thoroughly understand the markings on the pieces in your particular box<sup>1</sup>.

**Exp. 2. To illustrate the principle of the balance.**

*Required:—Triangular prism of wood, half-metre scale, box of weights.*

#### DIRECTIONS.

A. Put a triangular block of wood on the bench, and balance a half-metre rule with its scale uppermost, on the edge of the block.

**Note** the point of support (Fig. 17, *F*) on the rule, so as to replace it quickly if it slips.

Place a 5 gram weight at each end of the rule and see whether they balance one another; if not, move one slightly until they do so.

**Note** the distance in millimetres between the middle of each weight and the point of support of the rule.

B. Find out where a 10 gram weight must be placed to balance 5 grams at the end of the rule, taking care not to alter the position of the rule on the block.

C. Repeat B, using 20 grams instead of 10 grams.

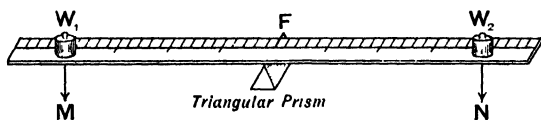

FIG. 17.

<sup>1</sup> It is desirable for beginners always to use the same box of weights until they are familiar with it. It is therefore useful to have the boxes numbered.



Find out for each of these cases whether the weight at one side *multiplied by* its distance from  $F$  = the weight on the other side *multiplied by* its distance from  $F$ .

These experiments will have shown you that equal weights will balance one another only if they are placed at equal distances from the point of support of the rule.

### LABORATORY NOTES.

Diagram, description, and numerical results.

*Questions*:—(i) If in Fig. 17  $W_1$  is 3 grams,  $MF$  20 cm., and  $W_2$  5 grams, calculate the distance  $NF$  when the weights balance.

(ii) If  $W_1$  is 7 grams,  $NF$  15 cm.,  $MF$  20 cm., calculate the weight of  $W_2$  when the weights balance.

### Exp. 3. To examine an accurate balance.

*Required*:—*Balance, paper, box of weights.*

#### DIRECTIONS.

A. Put a clean piece of paper on the bench.

Take off the pans, and lay them on the right- and left-hand sides of the paper.

Lift the wire pan-holders from the stirrups which support them, and put them by their pans.

Take off the stirrups, and put them in their proper pans.

Now take hold of the knob at the centre of the beam, lift the beam from its support and lay it on the middle of the paper.

Examine, draw, and name each part of the balance.

**Note** the position of the knife-edges, and the planes on which they work, also the material of which they are made.

[In good balances these parts are usually of agate, a very hard stone, which does not rust like steel, but is easily chipped by careless use.]

[Over

Move the lever which works in the base board backwards and forwards, and note the effect.  
Replace the parts in their proper positions.

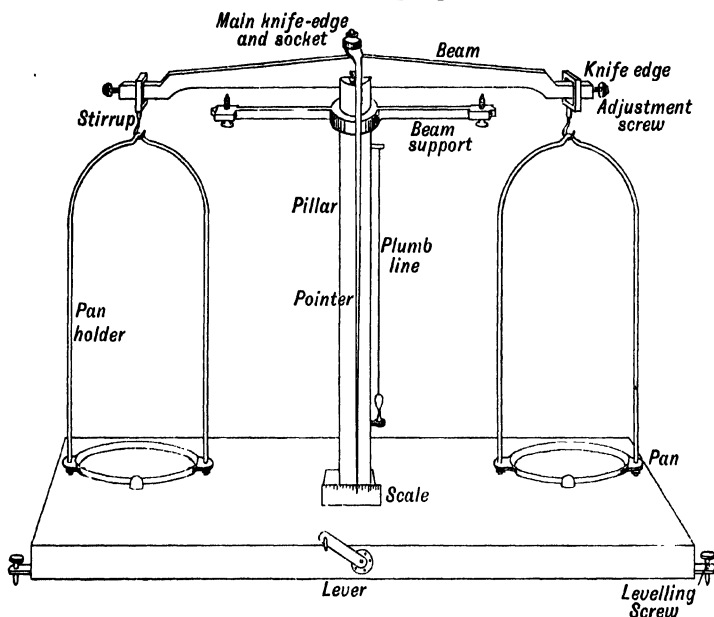

FIG. 18.

**B. ADJUSTMENTS.** (1) Notice the plumb-line hanging from one side of the pillar; this is to show whether the pillar is vertical.

If it is not vertical, turn the levelling screws until the point of the 'plumb' is just over the point fixed on the pillar.

(2) Turn the lever to the right, and set the beam swinging by gently fanning one pan with your hand.

**Note** whether the pointer moves over an equal number of divisions on the right and left of the middle mark on the scale. If it does not, turn the lever to the left, adjust the beam by screwing the nut at one end inwards or outwards as required, and try it again until correct.

**Precaution** :— *When adjusting the balance, and when adding or removing objects from the pans, the beam must always be at rest, i. e. the lever must be turned to the left.*

C. THE USE OF THE BRASS KNOB ON THE BEAM. Carefully unscrew and remove the brass knob.

With the aid of the forceps place a one gram weight in each pan. Set the beam swinging so as to be sure that the weights balance one another.

Add .01 gram to the right-hand pan, and again set it swinging.

**Note** whether the pointer indicates any difference in weight; if not, continue to add small weights until a difference is shown.

Replace the knob, and remove the decimal weights.

Now find the smallest additional weight which affects the swing of the pointer when the knob is in position.

The knob therefore increases the *sensitiveness* of the balance.

### RULES FOR WEIGHING.

(i) *Adjustments.*

(a) Adjust the levelling screws till the pillar is vertical.

(b) See that the stirrups rest properly on the knife-edges at the ends of the beam, and that the main knife-edge is in the socket.

(c) Set the beam swinging, and note whether the pointer swings over the same number of scale divisions on each side of the central line.

If not, adjust by means of the nut on the end of the beam.

[If the balance has a case, set the beam swinging and close the case to avoid disturbance by draughts.]

(ii) *The object to be weighed.*

(a) See that it is clean, dry, and cold.

(b) Take care that the beam is at rest when putting on or removing an object from the pans.

(c) Place it on the left-hand pan and the weights on the right. First try a weight which you think is a little heavier than the object; remove it if too heavy, and try smaller ones in order.

(iii) *The weights.*

(a) Never touch them with the fingers; always use the forceps.

(b) Pick up small weights by the turned-up edge.

(c) Arrange the weights on the pan right side up, so that the figures are easily read.

(d) Count up the weights<sup>1</sup> on the pan, and *check this result* by noting the weights absent from the box. Write down the total at once.

(e) Return them to the box, beginning with the largest.

#### **Exp. 4. Practice in weighing.**

##### DIRECTIONS.

Weigh carefully the following objects, all of which will be required for later experiments:—

A. The marked wooden block used in Exp. 10, p. 26.

B. The marked metal cylinder, used in Prob. 1, p. 27.

C. A small porcelain dish (50 c.c. capacity), previously marked on the rim with a file. (This dish should be carefully kept for future work.)

Count up the weights properly arranged on the pan. and check each result by counting the vacancies in the box.

##### **The Rider.**

The principle illustrated in Exp. 2 is used in a device for finding differences of weight less than a centigram.

The right-hand side of the beam of the balance, between the central and end knife-edges, is divided into ten equal parts

<sup>1</sup> Many mistakes are made by miscounting the weights. Besides being careful to arrange them tidily, it is useful to make a habit of always placing the decigrams in one row and the centigrams in another.

in the manner shown in Fig. 19. A piece of platinum or aluminium wire, weighing a centigram, is bent into the form shown at *R* in Fig. 19; this is called a rider.

If the centigram rider is suspended exactly over the end knife-edge it has the same effect as if it is placed in the pan on the same side, and it will balance an object weighing 1 cg. in the other pan. If however the rider is placed at any other point on the divided arm of the beam its effect is less than 1 cg. placed in the pan, and depends on its distance from the central knife-edge.

Thus if the rider is hung at the eighth division it will counterpoise .8 cg. in the left-hand pan, at the fifth division .5 cg., at the third .3 cg., and so on.

It is therefore possible, by using a centigram rider and having the beam on one side divided into ten parts, to find differences of weight of .1 cg., i. e. 1 mg. or .001 g.

In very delicate balances the beam is often divided into 100 equal parts, and with such a balance and using a centigram rider it is possible to find differences of weight of .01 cg., i. e. .1 mg. or .0001 g.

The method of using the rider is as follows:—

The object to be weighed is put in the left-hand pan and weights are put in the other until the addition of 1 cg. is found to be too much. The beam is brought to rest and the door of the balance is closed to exclude draughts.

The rider is now put on the beam by means of the carrier, and the latter having been raised, the beam is set swinging. If the pointer shows that the object is not counterpoised by the weights and the rider, the latter is moved until a position is found at which the two sides of the balance are exactly counterpoised.

**Questions** :—(i) How would it be possible to estimate the weight of an object to .1 cg., i. e. to .001 g., using the centigram rider and the beam divided in tenths?

(ii) What are the advantages gained by the use of the rider?

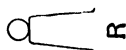
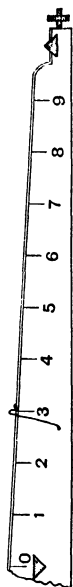

FIG. 19.

## EXAMPLES. IV.

1. How many cg. are there in (a) 1 g., (b) 1 dg., (c) 1 Kg. ?
2. Express 4.03014 Kg. in (a) grams, (b) hectograms, (c) milligrams.
3. Express 8009.1 cg. as (a) mg., (b) Hg., (c) Kg.
4. Write as decimals of a gram (a) 25 mg., (b) 6.5 cg., (c) .000067 Kg.
5. Add together 3.076 Kg., .508 Dg., .067 g., 16.01 cg., and express the total (a) in centigrams, (b) in kilograms.
6. Find the sum of 2 Kg. + 2 Dg. + 3 g. + 5 dg. + 4 cg., in (a) grams, (b) kilograms.
7. Find the sum of 20 mg. + 500 mg. + 10 cg. + 20 dg. Express as grams.
8. Subtract 25 mg. from 25.689 g., and express in grams.
9. What is the difference in grams between .01196 Kg. and 65.08 dg. ?
10. By how much does 67.8905 g. exceed 5.6081 Dg. ? Answer in grams.
11. How many dekagram weights could be made from 1 Kg. of brass ?
12. If 20 sovereigns weigh 1.4175 Hg., what is the average weight of one sovereign in grams ?
13. If 2.3 m. of wire weigh 9.5 decigrams, how many milligrams will 5 cm. of wire weigh ?
14. Taking 1 oz. (avoirdupois) = 28.35 g., find the number of (a) grams in 1 lb., (b) kilograms in 1 ton.
15. If 1 sq. cm. of paper weighs 1.5 cg., what is the area of a similar piece of paper weighing 5 dg. ?
16. 176.7 c.c. of a liquid weigh 205.6 g. What is the weight of 1 c.c. ?
17. What volume in c.c. would 200 g. of a liquid occupy when 1 litre of it weighs 1.405 Kg. ?

## CHAPTER V

### THE MEASUREMENT OF DENSITY

#### **Preliminary Questions on Density<sup>1</sup>.**

1. What do you understand by the expressions, 'lead is heavier than water,' 'cork is lighter than water'?

2. How would you attempt to find out if a given (*a*) solid, (*b*) liquid, was heavier or lighter than water?

3. State whether the following are heavier or lighter than water, giving the reasons for each statement:—(*a*) your own body, (*b*) ice, (*c*) an ironclad, (*d*) a fish.

4. Quicksilver is said to be  $13\frac{1}{2}$  times as heavy as water. Suggest a way of finding out whether this is true or not.

5. Supposing you had 1 c.c. of each of the following substances, arrange them in the order of their weights, beginning with the heaviest:—(*a*) olive oil, (*b*) lead, (*c*) water, (*d*) pine wood, (*e*) iron, (*f*) glass.

6. Supposing you had 1 kilogram of each of the substances mentioned in Question 5, arrange them according to their size, beginning with the smallest.

7. State what difference there is (if any) in (*a*) weight, (*b*) volume, between a pound of lead and a pound of wood.

8. Would you expect the weight of 1 c.c. of hot water to be greater, equal to, or less than that of 1 c.c. of cold water? Give reasons.

9. Calculate the mass of 1 c.c. of the wood composing the marked rectangular block used in Exp. 10, p. 26, and in Exp. 4, p. 66.

10. Calculate the mass of 1 c.c. of the metal composing the marked cylinder, the volume of which was found in Prob. 1, p. 27, and the mass in Exp. 4, p. 66.

<sup>1</sup> To be done in the Fair Notebook as explained on p. 3.

**Exp. 1. To find the weight of 1 c.c. of water at the air temperature.**

*Required:—Balance, 10 c.c. pipette, thermometer, small flask, weighed dish, tile.*

#### DIRECTIONS.

- A. Half fill a small flask with distilled water; put a thermometer in it.  
 Practise filling a 10 c.c. pipette exactly to the mark (see p. 35).  
 Clean the dish weighed in Exp. 4, p. 66, and put it on a clean tile.  
**Note** the temperature of the water in the flask.  
 Transfer 10 c.c. of the water from the flask to the dish.  
 Weigh the dish and water.
- B. Remove the dish from the balance, add 10 c.c. more water, and weigh again.
- C. Repeat B.

#### LABORATORY NOTES.

Arrange your results as follows:—

Temperature of water	=	° C.
A. Weight of dish + 10 c.c. of water	=	
Weight of dish . . . . .	=	
∴ weight of 1st 10 c.c. . . . .	=	----- X
B. Weight of dish + 20 c.c. of water	=	
"      "      + 10      "      "	=	
∴ weight of 2nd 10 c.c. . . . .	=	----- Y
C. Weight of dish + 30 c.c. . . . .	=	
"      "      + 20 c.c. . . . .	=	
∴ weight of 3rd 10 c.c. . . . .	=	===== Z



(If any result differs from either of the others by more than .1 g., repeat until three close results are obtained.)

$$\begin{aligned} \text{Total weight of 30 c.c.} &= X + Y + Z &= & \text{g.} \\ \therefore \text{mean weight of 10 c.c. at } t^\circ \text{C.} & &= & \text{g.} \\ \therefore \text{weight of 1 c.c. at } t^\circ \text{C.} & &= & \text{g.} \end{aligned}$$

- Questions*:—(i) Why is it better to use 10 c.c. of water and divide its weight by 10 rather than to measure out 1 c.c. and weigh it directly?
- (ii) If you were required to find the weight of 1 litre of water, explain whether it would be best to weigh the whole litre or to multiply the weight of 10 c.c. by 100 in order to get an accurate result.

### PROBLEMS (V. 1).

1. Using a burette, transfer 1 c.c. of water to a weighed dish, and find the weight of 1 c.c. directly. Repeat twice. Take the mean and compare it with the result of Exp. 1.

2. Devise a method of finding the weight of 1 c.c. of distilled water at about  $60^\circ \text{C.}$ , remembering that you must not weigh it while hot and that you must prevent the vapour from escaping, after you have found the volume of the water.

If approved, carry it out.

### Density.

Supposing that the temperature of the water used in Exp. 1 was  $15^\circ \text{C.}$ , that the work was accurately done, and the pipette correctly graduated, the weight of 1 c.c. of water would be .999 gram. This result is called the density of water at  $15^\circ \text{C.}$

At  $60^\circ \text{C.}$  the density is found to be .983 gram per c.c.; at  $4^\circ \text{C.}$  1 g. per c.c.; at  $2^\circ \text{C.}$  .999 g. per c.c. Thus we see that the density of water differs slightly at different temperatures. At no temperature is its density greater

than it is at 4° C., and for this reason water is said to have its highest or maximum density at 4° C.

Exp. 2 will show that different liquids have different densities, even when the temperature is the same.

For example, at 0° C. the following results have been obtained :—

Liquid.	Density.
Quicksilver (mercury)	13.596 grams per c.c.
Brine . . . . .	1.20    "    "
Glycerine . . . . .	1.260   "    "
Turpentine . . . . .	.870   "    "

DEFINITION. The **density of a substance** at any temperature is the number of units of mass contained in one unit of volume, or briefly, *Density is mass<sup>1</sup> of unit volume.*

### Specific Gravity.

Since the density of a substance is the mass of unit volume of it, the density of mercury at 15° C. may be expressed on the metric system as 13.56 grams per c.c., or 13,560 grams per litre; and on the English system as 7.828 ounces per cubic inch, or .489 lb. per cub. in. Thus the actual number representing the density depends on :

- (a) the unit of mass chosen ;
- (b) the unit of volume chosen.

Again, the density of water at 4° C. is 1 gram per c.c. in metric units, and .577 oz. per cub. in. in English units.

<sup>1</sup> The 'mass' of a body is found by 'weighing' it on a chemical balance. 'Mass' is often confused with 'weight.' For an explanation of the difference refer to a book on Dynamics.

If we want to find how many times the density of mercury at 15° C. is as great as that of water at 4° C., we divide the density of the former by that of the latter; both densities being in terms of the same units.

Thus on the metric system :

$$\frac{\text{Density of mercury at } 15^{\circ} \text{ C.}}{\text{Density of water at } 4^{\circ} \text{ C.}} = \frac{13.56 \text{ g. per c.c.}}{1 \text{ g. per c.c.}} = 13.56$$

$$\text{On the English system :} = \frac{7.828 \text{ oz. per cub. in.}}{.577 \text{ oz. per cub. in.}} = 13.56$$

The quotient representing the ratio of the densities is the same on both systems, viz. 13.56.

This number is called the *Specific gravity* (sp. g.) of mercury at 15° C., and does not depend on the units of mass or volume used for finding the densities.

**DEFINITION.** The **specific gravity of a substance** at any temperature is the ratio of its density at that temperature to the density of water at 4° C.

The sp. g. of a substance is a pure number, not the mass of a certain volume like density. Thus the sp. g. of mercury at 15° C. is 13.56, *not* 13.56 g. per c.c.

On the metric system it happens that the number expressing the mass of unit volume (i. e. density) is the same as that denoting the sp. g., because the mass of unit volume of water at 4° C. is the unit of mass (1 gram). On the other hand, in the English units chosen, the mass of 1 cub. in. of water at 4° C. is not 1 oz., but .577 oz., so that the number expressing the density as ounces per cub. in. differs from that denoting the sp. g.

It is important to remember the difference between density and specific gravity, especially as it is a common mistake to confuse them.

**Relative Density.**

If we find the ratio of the density of mercury at 15° C. to that of water at 15° C., instead of to that of water at 4° C., we get a number slightly different from the sp. g. of mercury at 15° C.

$$\text{Thus } \frac{\text{density of mercury at 15° C.}}{\text{density of water at 15° C.}} = \frac{13.56 \text{ g. per c.c.}}{.999 \text{ g. per c.c.}} \\ = 13.57$$

This number is called the relative density of mercury, and it is often wrongly called its specific gravity.

The difference between the two depends on the temperature at which the density of water is taken.

In determining the relative density of a substance the water may be at any convenient temperature, but in finding a specific gravity it must be at 4° C.

In stating a relative density the temperatures both of the substance and of the water should be given.

This is sometimes done shortly thus:—

$$\text{For mercury } {}_{15}\text{S}_{15} = 13.57,$$

which means that both the substance and water were at 15° C, and that the relative density at 15° C. is 13.57.

${}_{15}\text{S}_4 = 13.56$  means that the

$$\frac{\text{density of mercury at 15° C.}}{\text{density of water at 4° C.}} = 13.56,$$

i. e. 13.56 is the true specific gravity of mercury at 15° C.

Since water has its maximum density at 4° C., the exact specific gravity of a substance will always be slightly less than its density relative to water at any other temperature.

**Exp. 2. To find the relative density of liquids, using a relative density bottle.**

*Required:—Relative density bottle, balance, saturated solution of brine, methylated spirit, turpentine.*

#### DIRECTIONS.

Examine the bottle, noticing the marks engraved on it and the stopper.

Record the number of the bottle, and then weigh it.

Fill it with water so that both the bottle and the boring in the stopper are full.

**Note** the temperature of the room.

Carefully wipe it and weigh again.

Repeat the experiment with the other liquids, rinsing out the bottle with the new liquid before filling it.

#### LABORATORY NOTES.

Draw a diagram of the bottle and stopper.

Record weighings and deduce mass of each liquid.

Knowing the mass of water held by the bottle, calculate the relative density of each liquid.

Relative density at  $t$  C.

$$= \frac{\text{mass of liquid at } t^{\circ} \text{ C.}}{\text{mass of an equal volume of water at } t^{\circ} \text{ C.}}$$

Supposing Exps. 1 and 2 were done in a warm room, which method do you think would be most accurate, and why?

#### PROBLEMS (V. 2).

1. Test the accuracy of the graduations of a burette by running out 10 c.c. of water into a weighed dish. Reweigh and add another 10 c.c. Reweigh and run in a third 10 c.c.

**Note** (a) whether each 10 c.c. weighs the same ;

(b) whether the weight of 10 c.c. is 9.99 grams. <sup>1</sup>

2. Test the accuracy of the delivering capacity of a 25 c.c. pipette.

<sup>1</sup> If the weights of successive volumes (each 10 c.c. by the scale) vary, a table of corrections should be made. This process is known as *calibration*. All volume-measures should be calibrated before use for very accurate work. See Appendix, p. 177.

**Exp. 3. To find the density of shot at the air temperature.**

*Required:—Burette, balance, shot.*

### DIRECTIONS.

- A. In a weighed dish put about 30 grams of shot.  
Reweigh to obtain the exact weight of the shot.
- B. Set up a burette, and pour in distilled water.  
By opening the tap get the lower curve of the meniscus level with the 30 c.c. mark.  
Carefully drop the shot into the burette, and tap it gently to get rid of air bubbles.  
**Note** the exact level of the water.
- C. Wipe the weighed dish, and carefully run out the water from the burette till the level is again at 30 c.c.  
Weigh the dish and water.

### LABORATORY NOTES.

*Observations—*

A. Weight of dish + shot . . . . .	=	g.
Weight of dish . . . . .	=	g.
<i>∴ weight of shot taken</i> . . . . .	=	g.
B. Level of water in burette without shot . = c.c.		
"    "    "    containing shot =		c.c.
<i>∴ volume of shot</i> . . . . .	=	c.c.
C. Weight of dish + water . . . . .		
Weight of dish . . . . .	=	g.
<i>∴ weight of water having same volume as the shot</i> . . . . .	} =	g.

*Calculations—*

- (a) From A and B find the number of grams of shot in 1 c.c., i. e. the *density* of shot at the air temperature.

- (b) From *A* and *C* find the *relative density* of shot, i. e. divide weight of shot by weight of equal volume of water. This gives the number of times that 1 c.c. of shot is as heavy as 1 c.c. of water at a given temperature.

### PROBLEMS (V. 3).

1. Using a burette, find the relative density at air temperature of (a) lumps of *marble*, (b) *iron nails*, (c) *granulated copper*.

2. Given a piece of *lead* of known relative density how would you try to find the relative density of *cork*? If the method is approved, carry it out.

**Exp. 4. To compare the weight of a solid in air with its weight when suspended in liquids.**

*Required:—Glass stopper, thread, balance with bridge, beaker, measuring jar, methylated spirit, funnel.*

### DIRECTIONS.

A. Tie a piece of cotton to a marked glass stopper, and suspend it from the left-hand hook of the balance, so as to hang about 8 cm. above the pan.

Arrange a bridge over the pan, and an empty beaker as in Fig. 20.

Weigh the stopper in air.

B. Using a funnel, nearly fill the beaker with water; weigh the stopper now immersed in the water.

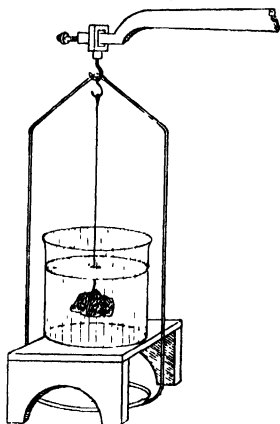

FIG. 20.

[Over

**Precaution:** Dislodge any air bubbles which cling to the stopper with a glass rod or small brush.

- C. Set the beam at rest, and remove the beaker; substitute methylated spirit for water, and replace the beaker on the bridge.

Weigh the stopper in methylated spirit.

- D. Find the volume of the stopper by immersion in a measuring jar partly filled with water.

**Precaution:** Be very careful to obtain accurate readings.

N.B.—Keep the stopper for further experiments.

### LABORATORY NOTES.

Diagram of balance arrangement.

Observations—

A.	Weight of stopper in air . . . =	g.
B.	„ „ „ water . . . =	g.
	∴ loss of weight in water . . . =	g.
	Weight of stopper in air . . . =	g.
C.	„ „ „ methylated spirit =	g.
	∴ loss of weight in methylated spirit =	g.
D.	Volume of stopper . . . =	c.c.

Calculate the weights of volumes of water and spirit equal to the volume of the stopper. (See notes on Exp. 2, p. 75.)

- Questions:—(i) In which liquid does the stopper weigh least?  
 (ii) Which liquid has the greatest density?  
 (iii) Compare (a) the weight of water equal in volume to that of the stopper with (b) the loss of weight in water.  
 (iv) Answer (iii), substituting 'methylated spirit' for 'water.'



- (v) Try to draw a conclusion from (iii) and (iv) about the loss in weight of a solid when weighed in a liquid.
- (vi) Using results of *A* and *D*, calculate density of the glass composing the stopper.
- (vii) Calculate the density of glass, using results of *A* and *B*.

### The principle of Archimedes.

The idea of finding the volume of an irregular solid by observing the volume of water it displaces is due to Archimedes, who lived in Syracuse about 220 B.C.

The king had sent some gold to be made into a crown, but he suspected that the goldsmith had mixed some silver with it, and asked Archimedes to find out if this was the case.

The latter was puzzled for some time how to do it without damaging the crown. The idea occurred to him as he was getting into a bath which was brimful: as he got in the water overflowed, and he saw that the volume of water would be the same as that of his own body. He saw that he could find the volume of the crown, and knowing its weight, could obtain what is now called its relative density. He could do the same for a piece of pure gold. The presence of silver in the crown would make its relative density less than that of gold, because the density of silver is less than that of gold.

Archimedes also found that a solid weighs less in water than in air, and further, that it weighs less in water by the weight of a volume of water equal to that of the solid.

In other words,

Weight of a solid in water = weight in air – weight of an equal volume of water.

This important discovery is known as the Principle of Archimedes, and is sometimes expressed thus:—‘*When a solid is immersed in a liquid it experiences an upthrust equal to the weight of the liquid displaced.*’

This gives a convenient way of finding the relative density of a solid, provided it does not dissolve in water.

It may be remembered shortly thus:—

$$\text{Relative density of a solid} = \frac{\text{Weight in air}}{\text{Loss of weight in water.}}$$

### PROBLEMS ON THE PRINCIPLE OF ARCHIMEDES (V. 4).

*Required* :—As in *Exp. 4* and for (1) lump of lead, (2) thin wire, (3) turpentine, (4) turpentine and crystals of some substance soluble in water.

1. Find the density of a piece of lead by weighing in air and then in water.

2. Find the area of cross-section of a piece of thin wire. Take 4 metres, coil it up, and weigh it in air and water. The loss of weight in water gives the volume of the wire in c.c.

3. Find the density of turpentine by weighing in it the stopper used in *Exp. 4*. The upthrust due to the liquid gives the weight of turpentine having the same volume as the stopper. Use results of *Exp. 4* for the calculation.

4. Find the density of a crystal (blue vitriol or alum) soluble in water. Use turpentine, and from the result of the last problem calculate the volume of the crystal.

**Exp. 5.** To find the relative density of a liquid, using a U-tube.

*Required:*— U-tube (limbs 30 cm. long, diameter of tube 1 cm.), clamp, tray, turpentine, water.

### DIRECTIONS.

Clamp the U-tube vertically on a stand, and place the whole on a tray.

Pour water down one limb until half full.

Compare the levels of water in the two limbs.

Now pour some turpentine down one limb until it is nearly full.

Measure the vertical height from the tray to—

(a) the free surface of the water (A, Fig. 21);

(b) the surface of contact B;

(c) the free surface of turpentine C.

By subtraction, find CB and AB'.

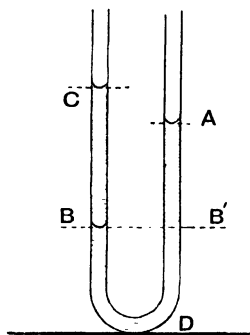

FIG. 21.

### LABORATORY NOTES.

Diagram and neat record of measurements.

*Questions:*— (i) When water alone was in the tube what were the relative heights of the free surfaces in each limb?

(ii) State the lengths of the columns of water and turpentine which balance one another.

(iii) Is turpentine denser or less dense than water?

- (iv) Taking  $h$  and  $h'$  as the lengths of the columns of two liquids which balance one another, and  $d$  and  $d'$  as their respective densities, devise a formula to calculate

the relation  $\frac{d'}{d}$ .

- (v) Work out the density of turpentine relative to that of water.

### PROBLEMS (V. 5).

1. Find the relative density of *mercury*, using a U-tube.
2. Devise a method for determining the relative density of *alcohol* with a U-tube, remembering that since alcohol and water mix, they should be separated by a small quantity of mercury.

### Exp. 6. Further experiments with the U-tube.

*Required:—As in Exp. 5, funnel, narrow straight rubber connectors, glass tube (·5 cm. diam.).*

### DIRECTIONS.

- A. Set up the U-tube as in Exp. 5, and half fill with water; alter the clamp so as to hold the tube at a slope.  
Compare (a) the *vertical* heights of free surfaces of the water in each limb above the tray, and (b) the volumes of water in each limb.
- B. Clamp the tube vertically, and to one limb fasten (by rubber connectors) a funnel, and to the other a straight tube of narrower bore than the U-tube.  
Pour in more water till the funnel is half full.  
Compare the heights of the water column above the middle point of the bend, and state which column contains the greatest weight of water.

## LABORATORY NOTES.

Diagrams and observations for both *A* and *B*.

Try to account for the facts observed as to the vertical heights of the free surfaces, in view of the fact that the weights of the water in the limbs were unequal.

**Pressure exerted by solids and liquids.** Exps. 5 and 6 introduce the subject of fluid pressure. As subsequent work involves a knowledge of pressure, it is important to have a clear idea of the meaning of the term.

It is a matter of common knowledge that a solid can be pressed by putting weights on the top of it. The heavier the weights, the greater is the pressure exerted on the solid. The solid is said to be compressed (i. e. made to occupy less volume) by the process.

Pressure is not, however, the same as 'weight' or 'force,' but is *the force acting on unit area*. Thus a man standing on both feet exerts a certain pressure on the ground immediately under them. If he stands on one foot, the pressure on the ground under that foot is double what it was before, because the same weight is acting on half the former area. If a weight of 160 lb. is acting on a surface 10 sq. in., the pressure is  $\frac{160}{10} = 16$  lb. per sq. in.

**Transmission of pressure.** Pressure can be transmitted through an incompressible body to another. In solids the transmission takes place only in the direction in which the force acts. Thus, if a nail has to be driven vertically into a board, the best effect is produced by hitting it vertically downwards with a hammer. The pressure produced by the blow of the hammer on the head is transmitted through the nail to the board. But if the nail be struck with a horizontal blow, it is not driven further into the wood.

It is quite different with fluids (i. e. liquids and gases). If a jar full of water has a hole at the side, the water runs out until the level of the water is no longer above the

hole. This shows that the water is pressing horizontally against the sides as well as vertically downwards.

The experiments on the principle of Archimedes have shown that liquids are capable of exerting an upward pressure, which diminishes the apparent weight of a solid. It can be shown by other experiments that a fluid exerts an equal pressure in all directions at a given point within it.

Suppose we have a column of six centimetre cubes, one on the top of the other, standing on a table. If each cube weighs 1 g., the pressure exerted by the column is 6 g. per sq. cm. The pressure on the upper surface of the fourth from the top is 3 g. per sq. cm. In general the pressure at any point in the column is equal to the weight of the part of the column *above* the point divided by the area of the surface on which it is resting. If the density of each cube were 1.5 g. per c.c., the pressure on the table would be  $6 \times 1.5 = 9$  g. per sq. cm. Thus the pressure depends on the density of the material. Now suppose instead of cubes we have a column of water in a jar of 1 sq. cm. cross-section. If the height of the column is 6 cm., the pressure at the base is 6 g. per sq. cm. If mercury replaces the water, the pressure at the base would be  $6 \times 13.6 = 81.6$  g. per sq. cm., since 1 c.c. of mercury weighs 13.6 g.

In general, the pressure exerted by a liquid at a point in the liquid depends (*a*) on the depth of the point below the surface, (*b*) on the density of the liquid.

The difference between the case of the solid and liquid is that in the latter the pressure acts not only vertically downwards, but equally in all directions.

By means of a U-tube a column of one liquid may be balanced against another, and their densities compared.

When the tube is placed as in Fig. 21, if  $h$  and  $h'$  be the lengths of the columns of the two liquids above their surface of contact, and  $d$  and  $d'$  their densities, and  $a$

the area of cross-section, the pressures at the base of each column are  $\frac{hda}{a}$  and  $\frac{h'd'a}{a}$ . These are equal, hence  $hd = h'd'$ .

Exp. 6 showed that the width of the tube made no difference to the heights of the balancing columns. The extra weight of water in the funnel was supported by the sloping sides. Also when the tube is slanting the vertical heights of the surfaces are equal for the same liquid, although the weights of liquid in the two limbs may be unequal. In this case more support is given to the liquid in one limb by the sloping side than in the other. The pressure at the lowest point in the sloping tube is less than when vertical, and depends only on the vertical height of the free surface above this point, and on the density of the liquid.

Hence, the pressure exerted by a liquid at any point in a column of it depends on—

(a) the density of the liquid ;

(b) the height of the free surface above this point.

It does not depend on the width of the tube.

### QUESTIONS ON CHAPTER V.

1. If 75 c.c. of iron weigh 568.5 g., find the density of iron.
2. Taking the density of copper as 9 g. per c.c., find the volume of 1 Kg. of copper.
3. A certain volume of alcohol weighed 96 g. and the weight of the same volume of water at the same temperature was 120 g. Calculate the relative density of the alcohol at this temperature.
4. A bottle weighing 20 g. weighs 45 g. when filled with water at 15° C. When filled with mercury at 15° C. it weighs 360 g. Find the relative density of mercury at 15° C.
5. A copper cylinder is 3.78 cm. long and has a diameter of 1.56 cm. Its weight is 64.54 g. Calculate its density.
6. Explain why it is easier to float in sea water than in fresh water.
7. If air has weight like water, is the value for the weight of an object weighed in air the correct value? Give a reason.

[Over

8. What weight of olive oil of density  $.87$  g. per c.c. would have the same volume as  $20$  g. of glycerine of density  $1.26$  g. per c.c.?

9. What would be the area of a sheet of gold leaf  $.001$  mm. thick beaten from  $10$  g. of gold of density  $19$  g. per c.c.?

10. Find the weight, when suspended in alcohol of density  $.8$  g. per c.c., of a piece of gold which weighs  $10$  g. in air.

11. What is the pressure on the bottom of a cylinder of  $2$  cm. radius when it contains a column of glycerine  $20$  cm. long? Density of glycerine  $1.26$  g. per c.c.

12. Find the pressure per sq. cm. at a depth of  $30$  m. below the surface of the sea, the density of sea water being  $1.026$  g. per c.c.

13. Glycerine is poured into the U-tube shown in Fig. 21. Petroleum having a density of  $.82$  g. per c.c. is poured into one limb until a column  $16$  cm. long is formed. The column of glycerine ( $AB'$  in Fig.) which balances the column of petroleum is  $10.6$  cm. long. Find the relative density of glycerine.

14. A piece of cork having a volume of  $10$  c.c. is put into water in a measuring jar. The level of the water at first stood at the  $50$  c.c. mark and after the addition of the cork at  $52.4$  c.c. Find the relative density of cork, if  $1$  c.c. of water at the temperature of the experiment weighs  $.99$  g.

15. A piece of rock crystal weighs in air  $15$  g. and when suspended in water  $9.407$  g. Find the relative density of rock crystal.

16. A crystal of Epsom salt is found to weigh  $6.77$  g. in air, and suspended in turpentine  $4.595$  g. If the density of turpentine is  $.87$  g. per c.c., find the density of Epsom salt.

17. A block of ice having a volume of  $30$  c.c. is put into water at  $0^{\circ}\text{C}$ . If the densities of ice and water at  $0^{\circ}\text{C}$ . are respectively  $.93$  g. and  $.99$  g. per c.c., find what volume of ice is immersed in the water.

18. A bottle weighing  $20$  g. weighs  $45$  g. when filled with water at  $15^{\circ}\text{C}$ .  $5$  g. of copper filings is then put into the bottle, which is again filled with water; it is now found to weigh  $49.419$  g. Find the density of copper. The density of water at  $15^{\circ}\text{C}$ . is  $.99$  g. per c.c.

19. Describe some method by which you would try to find the relative density of your body.



## CHAPTER VI

### SOLUTIONS

#### **Preliminary Questions on Solution<sup>1</sup>.**

1. What happens to a lump of sugar when put in a glass of water and allowed to stand for some time?

2. What difference would there be in the effect if the water were (a) stirred, (b) heated?

3. If a glass, containing very little water, were filled up with sugar, would the same effect be observed?

4. Why does sea water taste like salt?

5. Can salt be got from sea water? If so, how?

6. If you were given some muddy water, how would you separate the water from the mud?

[When particles of mud or other solids are floating about in a liquid, they are said to be 'suspended' in the liquid.]

7. What do you understand by the words 'solution,' 'solvent,' and 'dissolve'?

8. What difference is there between 'melting' and 'dissolving'?

9. Do you know of any cases where two liquids after being shaken together and then allowed to stand (a) do, (b) do not, separate into two layers? If so, state how you would attempt to separate the two liquids in each case.

10. Do you think one liquid can dissolve another? Give reasons.

11. Give reasons, based on any observations you have made when water is heated, for thinking that water dissolves air.

<sup>1</sup> Copy out and answer as many as possible of the questions in your Fair Notebook, from your own general knowledge, and without any help.

**Exp. 1. To separate (a) suspended, (b) dissolved, solids from the liquid containing them.**

*Required:—4 test-tubes, test-tube stand, salt, small beaker or water-bath<sup>1</sup>, 2 watch-glasses or porcelain basins, glass funnel, filter-paper, sand-bath.*

### DIRECTIONS.

A. Put some powdered salt into a test-tube labelled *W*, till it occupies about a third of the tube.

Add distilled water till tube is two-thirds full, and shake for five minutes.

While the solid particles of salt are still floating about in the water, pour off half the mixture into another tube labelled *X*, and allow it to stand.

Take a circular piece of filter-paper, bend it exactly in two, and then in two again. Open it out into a cone, and place it in a glass funnel, so that it fits well.

Moisten the paper with a little water to make it keep its place.

Put the stem of the funnel in the mouth of another test-tube (*Y*), and after shaking *W*, pour its contents on to the paper in the funnel.

**Note** what happens to (a) the solid, (b) the liquid.

This process is called *Filtration*.

B. Pour a few drops of the clear liquid in *Y* (called the *filtrate*) into a watch-glass (or small porcelain basin).

Place the latter on a sand-bath standing on a tripod, and heat with a small flame; remove the burner when the liquid has nearly all gone.

<sup>1</sup> English-made enamelled mugs,  $3\frac{1}{2}'' \times 3\frac{1}{4}''$ , with one ring  $2''$  internal diameter, are useful for this purpose.

**Note (c)** whether any solid remains after the water has gone;

(d) whether any solid is lost by 'spiriting.'

This process is called **Evaporation**, because the water goes off in the form of vapour.

C. Now examine the contents of X.

**Note (e)** whether the salt has settled, leaving a clear liquid above it.

If so, take a glass rod, hold it over the mouth of another clean tube (Z) with the left hand, and without shaking X pour the clear liquid down the rod.

Stop before any solid is poured out.

This process is called **Decantation**, and the clear liquid is said to have been 'decanted' from the solid.

D. Pour a few drops of clear liquid from Z into a watch-glass (or basin), and place this on the top of a water-bath or a small beaker half filled with water.

Put the bath or beaker on a tripod covered with gauze, and heat it.

Leave the water to boil, so that the steam heats the watch-glass (or basin), causing the liquid to evaporate<sup>1</sup>. Continue till no liquid remains.

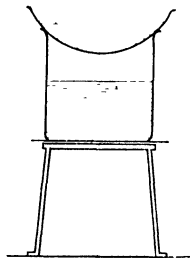

FIG 22.

### LABORATORY NOTES.

Observations on A, B, C, and D. Diagram for D.

**Questions:**—(i) Name two ways of separating a solid from the liquid in which it is suspended.

(ii) Which do you think is the best for getting *all* the solid free from the liquid, and why?

<sup>1</sup> This may take some time, but if necessary the basin may be covered with paper and left for the next lesson.

- (iii) What forms of apparatus can be used for evaporating a liquid?
- (iv) Which is the quickest method?
- (v) Which is the best if you want to obtain all the solid without loss by spirting?
- (vi) What is the solid obtained in *B*?
- (vii) How was it that it came through the filter-paper?

### PROBLEMS (VI. 1).

*Required*:—Salt, thermometer, nitre, 'hypo,' alum.

1. Evaporate some clear tap water in a watch-glass, and find if there is any solid residue by rubbing the dry glass with the finger.

Repeat, using distilled water.

2. Half fill a test-tube with distilled water, and add a *very small* pinch of salt. Shake for five minutes, and note whether any solid is left. If so, add more water and shake again. If not, explain what has become of it, and do a further experiment to test the truth of your answer.

3. Half fill a test-tube with distilled water, and take its temperature. Keep the tube in a stand, and avoid heating it with your hand. Add a fair quantity of salt, stir gently with thermometer, and note temperature again. Try to explain the result. (If in doubt refer to Exp. 5, p. 56, for a clue.)

Repeat with other soluble solids, such as 'nitre,' 'hypo,' 'alum.'

4. Devise a way of altering the process of evaporation so that the liquid can be recovered as well as the dissolved solid. If approved, proceed with your method; if not, do Exp. 2. Use tap water.

### Solutions of Solids in Liquids.

The filtrate used in Exp. 1 (*B*) was a solution of salt in water. We know there was salt in it, because solid salt remained in the vessel after evaporation; yet the salt while in solution was not solid, for if it had been so we could have seen it, and it could not have passed

through the filter-paper. Hence when salt is dissolved in water it must be in the liquid state. Now we know that heat will transform most solids to the liquid state, but the melting-point of salt is very high, and as no heat was used in making the solution, the liquefaction cannot be due to heat.

We have therefore to recognize two ways in which a solid can be liquefied:

- (a) by the action of heat alone, called melting or fusion;
- (b) by the action of a liquid (with or without heat), called dissolving.

The experiment (1 A) also showed that although some of the salt dissolved in the water, some of it did not, and no amount of shaking or standing will cause any more to dissolve.

We thus see that a given quantity of water will only dissolve a certain amount of salt. Where a liquid has dissolved as much solid as it can, the solution so formed is called a **saturated solution**.

Another conclusion to be drawn from the experiment is, that filtration only removes floating or suspended solid matter from a liquid; it does not remove that part of the solid which has dissolved. If we wish to obtain a solid from its solution we must evaporate the latter, when the liquid goes off as vapour, and the solid is left behind.

Problem 1 (p. 90) shows that ordinary water from the tap is not pure water, but a solution of some solid or solids. Since it is necessary to have pure water for our experiments on solutions, and for most chemical experiments, it is important to know how to obtain it free from dissolved solids. The principle of the method is to modify the process of evaporation so as to collect and condense the steam. Such a process is called **Distillation**.

**Exp. 2. To obtain pure water from ordinary tap water.**

*Required:—Retort fixed on stand, flask resting on ring above a sink, gauze.*

#### DIRECTIONS.

Set up the apparatus shown in Fig. 23.

Pour tap water into the retort until two-thirds full, and boil it. (If it boils violently, add two or three pieces of clay-pipe stem, and observe the effect.)

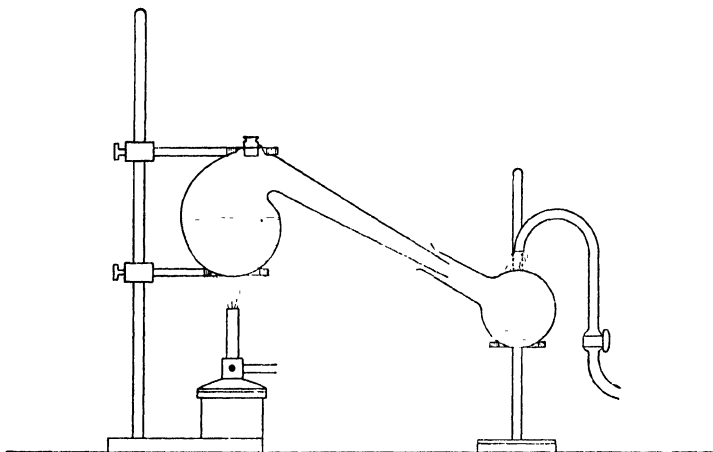

FIG. 23.

Turn the flame down if it begins to boil too violently again.

Throw away the first portion of the liquid (*distillate*) which collects in the flask.

Remove the lamp when about four-fifths of the liquid has been distilled.

Evaporate a portion of the distillate on a watch-glass.

**Note** whether there is any residue.

(If there is, it must be redistilled with greater precautions against violent boiling.)

#### LABORATORY NOTES.

Descriptive diagram and record of observations.

Questions :—(i) Why was the first portion of the distillate thrown away?

(ii) Why was the liquid in the retort not boiled to dryness?

(iii) What is the chief objection to this form of apparatus?

**Exp. 3. To distil liquids with improved apparatus.**

*Required:—Apparatus as shown in Fig. 24 and Fig. 15, p. 59.*

#### DIRECTIONS.

Fig. 24 shows the apparatus. Cold water is supplied at B and warm water escapes at A. This arrangement is known as Liebig's condenser.

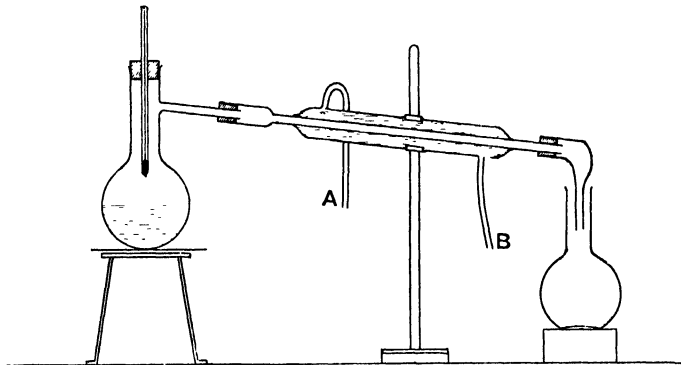

FIG. 24.

Distil some blue vitriol solution.

**Note** the reading of the thermometer when the bulb is in  
 (a) the boiling solution ;  
 (b) vapour above the solution.

Test the boiling-point of the distillate, using apparatus of Exp. 7. p. 59.

#### LABORATORY NOTES.

Diagram, descriptions, and observations.

- Questions:—*(i) What are the improvements in apparatus of Exp. 3 over that in Exp. 2 as regards (a) condensing the steam, (b) the prevention of 'spiriting' ?
- (ii) Why is it necessary for the cold water to enter at B (Fig. 24) and not at A, in the condenser ?
- (iii) Is the temperature of the boiling solution greater than, equal to, or less than that of the vapour produced ?
- (iv) How do these temperatures compare with the boiling-point of the distillate ?

**Distillation on a larger scale.**

The process of distillation is largely used in chemical experiments, and in the manufacture of substances.

Fig. 25 shows an apparatus for distilling water on a larger scale, often used in a laboratory.

The still (which corresponds to the retort of Exp. 2 and the boiling flask of Exp. 3) is usually made of copper coated inside with tin, and is heated by a gas-burner placed underneath. The steam from the boiling water passes into a spiral tube (or worm) placed in a cylinder

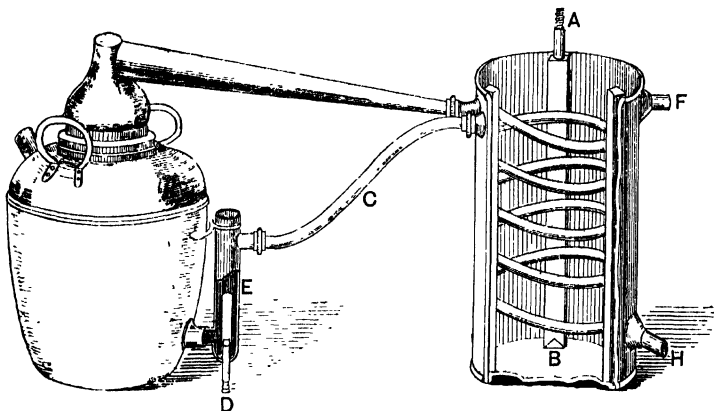

FIG. 25.

containing cold water. Here it condenses to water, and is collected in a vessel placed to receive it at *H*.

The cold water surrounding the worm gradually becomes hot, and must therefore be constantly replaced. This is done by allowing fresh cold water to enter at the bottom of the cylinder by the pipe *AB*; the warmer water rises to the top, and some passes down the pipe *C*, which feeds the still with comparatively warm water. By this device the boiling in the still is not checked, as it would be if water from the feeding pipe were quite cold.

The excess of water above a certain level can flow away through *D*. *F* is a safety overflow in case the water



entered through *AB* so quickly that the tube *C* could not carry it off fast enough. By these arrangements the water can be distilled continuously and without attention when once the cold-water supply at *A* has been turned on and the burner under the still lighted.

**Exp. 4. To show the influence of temperature on the solubility of a solid.**

*Required* :—*Test-tubes, powdered alum.*

#### DIRECTIONS.

Make a *saturated* solution of alum in a test-tube, using cold distilled water.

Start with the tube half full of water, add small quantities of powdered alum, shaking well after each addition.

Continue till no more will dissolve, a little undissolved solid remaining in the tube.

Heat it gently, shaking it from time to time.

**Note** whether the residue dissolves now or not.

If it dissolves add more alum, and continue to heat.

Cool the hot solution under the tap. **Note** what happens.

#### LABORATORY NOTES.

Observations.

(Full description for Fair Notes.)

*Questions* :—(i) Is a cold saturated solution of alum in water still saturated when warmed?

(ii) Explain the effect noticed on cooling the hot saturated solution.

(iii) Do you think the same effect would be noticed if the cold saturated solution had been heated without further addition of alum, and then cooled? Give reasons. (If in doubt, try it.)

**Exp. 5. To test the solubility of various solids in cold and hot water.**

*Required* :— 6 test-tubes, 3 watch-glasses, (a) nitre, (b) borax, (c) plaster of Paris, (d) lime, (e) chalk, (f) white sand, (g) blue vitriol, (h) Epsom salt, (i) sulphur, (j) iodine, (k) paraffin wax, (l) camphor, (m) powdered charcoal, (n) powdered glass.

### DIRECTIONS.

[Each member of the class should try at least seven of these solids, starting with (a) or (b), and then taking the *alternate* ones if there is not time to do all.]

A. Use a test-tube half full of distilled water, add an *extremely small* quantity of the solid, and shake.

**Note** whether it dissolves or not.

If it does, add a little more and shake again.

**Note** roughly how much dissolves, so as to compare the solubility of the different substances you use.

**Precaution** : It is very important to start with a *minute* portion of the solid, adding more afterwards if necessary.

B. Warm the tube.

**Note** whether heating increases the solubility or not.

If any substance seems insoluble, even after heating, filter it, and rapidly evaporate some of the filtrate on a watch-glass over a sand-bath to find whether it is really quite insoluble or only very sparingly soluble.

## LABORATORY NOTES.

Enter your observations in a scheme thus:—

Name of substance.	Cold water.	Hot water.	Other observations.
	(State whether it seems very soluble, fairly soluble, or insoluble.)	(Enter as under cold water, and also state whether the solubility seems to increase or not.)	(Colour of solution and any peculiarities noticed.)

**Exp. 6. To ascertain the solvent power of other liquids.**

*Required:— Clean sand, sulphur, paraffin wax, camphor, iodine, powdered charcoal, chalk, powdered glass, alcohol, light petroleum, benzene, 6 test-tubes, water-bath.*

## DIRECTIONS.

Repeat Exp. 5, using four of the above solids and the following liquids:—alcohol, light petroleum, benzene.

First try with the liquid at the air temperature, and afterwards warm it by putting the tube in a bath of hot water.

**Precaution:** *None of these liquids must be heated by a flame; all lamps must be turned out.*

## LABORATORY NOTES.

Scheme for observations, as in Exp. 5.

*Questions:—*(i) What substances appear insoluble in all the liquids you tried?

(ii) Name those insoluble in water but soluble in some other liquid. Give names of liquids.

(iii) Give reasons for the precaution.

## PROBLEM (VI. 6).

Test the solubility of sulphur in *cold* carbon bisulphide.

Filter and evaporate on a water-bath. (No flame to be used.)

**Solubility.** It will be understood from Exp. 5 that some solids are insoluble, some slightly soluble, and others very soluble in water; while Exp. 6 will have shown that some of the solids which are insoluble in water will dissolve in other liquids. Both experiments under the conditions in which they were carried out could only give a *rough* idea of the extent of the solubility of any one substance in a given liquid. In order to obtain an *exact* idea of the extent of the solubility of solids, some definite way of comparing solubilities must be decided upon, and a definite meaning given to the word 'solubility.'

The following definition shows how this has been settled:—

**DEFINITION.** The **solubility of a solid in a liquid** at a given temperature is the number of grams of solid which dissolve in 100 g. of the liquid to form a saturated solution at that temperature.

It is useful to remember that solutions in water are often called 'aqueous solutions,' and those in alcohol, 'alcoholic solutions' or 'tinctures,' e. g. tincture of iodine.

**Exp. 7. To find the solubility of a solid in water at different temperatures.**

*Required:—2 flasks of 50 c.c. capacity, weighed dish, water-bath, nitre, tile, thermometer.*

*A. At the temperature of the laboratory.* Take about 30 c.c. of distilled water in a flask and make a cold saturated solution of the powdered solid, as in Exp. 5.

Filter (or decant) from the undissolved solid.

**Note** the temperature of the filtrate.

Clean your weighed dish, and pour into it a small quantity (about 10 c.c.) of the solution.

Weigh again.

Evaporate to dryness on a water-bath.

Wipe the outside of the dish, allow it to cool on a tile, and weigh again when quite cold.

Record the results as follows:—

Temperature of solution	=	° C.
A. Weight of dish + solution	. =	g.
Weight of dish . . .	. =	g.
<i>Solution weighs . . .</i>		g. (X)
-----		
Weight of dish + dry solid	. =	g.
Weight of dish . . .	. =	g.
<i>Solid left weighs . . .</i>		g. (Y)
-----		
<i>Weight of water = X - Y</i>	=	g. (Z)
=====		

Calculate the weight of nitre dissolved by 100 g. of water.

*B. At some other temperature*<sup>1</sup>. Take a water-bath, large enough to hold the flask, and heat the bath a little above the given temperature.

<sup>1</sup> In this experiment it is advisable for pupils to work in pairs, each pair taking a different temperature at intervals of 5 or 10 degrees between 15° C. and 65° C. The general results can be plotted on squared paper. (See p. 101.)

Turn the flame low to keep the temperature constant. Now make a saturated solution of the solid at this temperature.

Proceed as in *A*, but keep the flask in the bath, and add solid gradually till no more dissolves.

**Precaution:** Be quite sure that the liquid is saturated before proceeding.

*If the excess of solid settles quickly*, take the temperature of the solution exactly, and quickly transfer some of it (about 10 c.c.) into a small flask which has been weighed with a cork. Press the cork into the mouth, and set it aside until it is quite cold, and then weigh it again.

*If the solid does not settle*, fit a funnel with a filter-paper, warm and place the funnel in the mouth of the weighed flask; and having taken the temperature of the solution, pour some of it on to the filter-paper. When enough of the clear solution has run into the flask, remove the funnel, cork the flask, and when it is cold, weigh it.

Pour the contents of the flask into the weighed porcelain basin, and rinse out the flask into the basin with distilled water at least twice, using a small quantity of water for each rinsing.

Now set the basin on a steam-bath, leave it until the liquid has evaporated to dryness, and weigh it as soon as it is cold. Record results as follows:—

Temperature of solution = ° C.

<i>B.</i> Weight of flask + solution	. =	g.
Weight of flask	. . . =	g.
<i>Weight of solution</i>	. . . =	g. (X)
Weight of dish + solid	. =	g.
Weight of dish	. . . =	g.
<i>Solid left</i>	. . . =	g. (Y)
∴ <i>weight of water</i> = X - Y	=	g. (Z)

Calculate weight of solid dissolved by 100 grams of water at  $^{\circ}\text{C}$ .

Diagrams of apparatus used and notes on any difficulties met with.

### PROBLEMS (VI. 7).

1. Determine the solubility of *common salt* or *Epsom salt* at  $20^{\circ}\text{C}$ .,  $40^{\circ}\text{C}$ ., and  $60^{\circ}\text{C}$ .

2. Find the solubility of *paraffin wax* in *light petroleum* at the temperature of the laboratory, remembering that the wax melts below  $100^{\circ}\text{C}$ . and petroleum boils at about  $45^{\circ}\text{C}$ .

#### To plot a curve of solubility.

The results of the last experiments show that an increase in temperature causes an increase in the solubility of a solid, as a rule.

Both the solubility and temperature are expressed in numbers which could be written in two columns to show how solubility alters with temperature.

This connexion between the two sets of numbers is seen much better by 'plotting' a solubility curve on squared paper.

On a piece of millimetre squared paper, take two axes at right angles, such as  $AB$  and  $BC$  (Fig. 26).

Place a dot  $x$  on  $AB$  at a distance in millimetres from  $B$  equal to the solubility value; on  $BC$  place a dot  $y$  at a distance from  $B$  representing the temperature at which this solubility was determined.

(If the temperature values are as much as ten times the solubility values, it is better to measure off the solubility with a centimetre for the unit, keeping a millimetre as the unit for temperature.)

Find a point where lines drawn at right angles to  $AB$ ,  $BC$  from  $x$  and  $y$  intersect. Draw a small circle  $p$  at this point<sup>1</sup>.

<sup>1</sup>  $By$  is called the *abscissa*, and  $py$  the *ordinate*, of the point  $p$ .

Repeat this operation for the other values.

A number of points have now been plotted, amongst which a line can be drawn called the curve of solubility.

Place the hand on the inside of the curved line of circles, and starting from the left-hand circle, draw a curve which passes through as many of the circles as possible.

This curved line is the curve of solubility for the solid in the given liquid.

It will be seen that the line does not touch all the circles; some are nearer, and others are further from it.

This is because all the results are not accurate; any result the position of which deviates widely from the curve is probably (though not certainly) wrong.

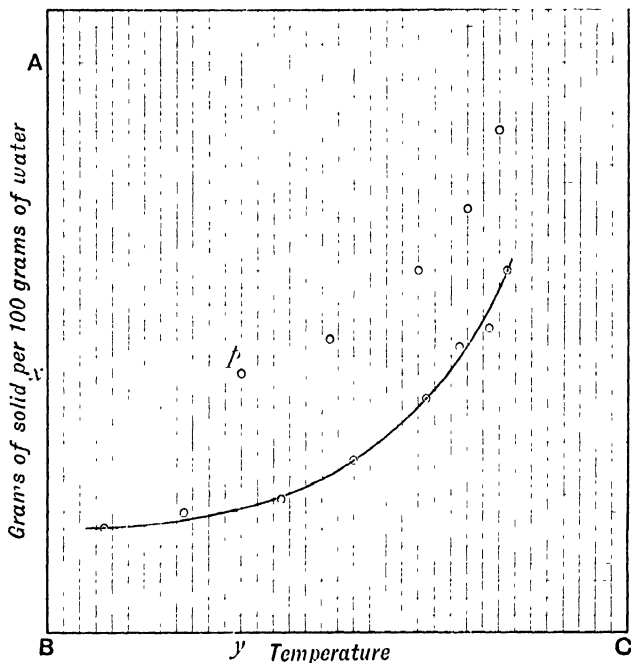

FIG. 26.



## EXAMPLES VI (a).

1. 10 c.c. of a solution of salt in water (at the air temperature) weighed 11.8 g. After evaporation 3.04 g. of salt remained. Calculate the solubility of salt in water at this temperature.

2. Draw a solubility curve for nitre from the following data :—

Temperature	0°	10°	20°	30°	40°	50°	55°
Solubility .	13	21	31	45	64	86	100

3. From the curve drawn in the last question find—

(a) the solubility of nitre at 45° ;

(b) the temperature at which 100 g. of water are saturated by 25 g. of nitre.

4. Draw a solubility curve for Epsom salt from the following data :—

Temperature	0°	10°	20°	30°	40°	50°	60°	70°	80°	90°	100°
Solubility .	26.9	31.5	36.2	40.9	45.6	50.3	55	59.6	64.2	68.9	73.8

5. If 173.8 g. of the solution saturated at 100° C. are cooled to 15° C., what weight of Epsom salt would separate out?

6. The following data give the solubility of lead chloride at various temperatures :—

Temperature	0°	10°	20°	40°	55°	80°
Solubility .	.8	.916	1.18	1.7	2.1	3.1

Draw a curve and estimate from it the solubility at 19° C. and at 30° C.

7. 100 g. of water is shaken at 40° C. for 15 minutes with 40 g. of a mixture of salt and lead chloride. The whole of the lead chloride is dissolved and 2 g. of salt is left undissolved. What was the composition of the mixture used? Solubility data for common salt :—

Temperature	0°	10°	20°	30°	40°	50°	60°	70°	80°	90°	100°
Solubility .	35.7	35.8	36	36.3	36.6	37	37.3	37.9	38.4	39.1	39.8

**Exp. 8.** To separate the soluble from the insoluble portion of a mixture of solids, and to find the percentage weight of each present.

*Required:—Mixture of potassium chromate and barium sulphate<sup>1</sup> in known proportions, beaker, weighed dish, gauze, funnel, tripod.*

#### DIRECTIONS.

Use a mixture of potassium chromate and barium sulphate.

You are required to separate these so as to obtain the whole of the barium sulphate and the whole of the chromate, both quite dry, and to find the percentage weight of each in the mixture.

Devise a method of doing it, being careful to state how you will get the barium sulphate free from traces of the yellow substance.

When your method has been approved, carry it out.

#### LABORATORY NOTES.

Description of method, diagram of apparatus, and record of observations.

*Questions:—*(i) What precautions were taken to remove the last traces of the yellow solution from the barium sulphate?  
(ii) Is it easier to get a pure specimen of (a) potassium chromate or (b) barium sulphate from the mixture?  
Give reasons.

#### PROBLEM (VI. 8).

Find the percentage of insoluble matter in the given mixtures of:

- (1) Finely powdered *shellac* and *silica* ;
- (2) *Sand* and *sugar*.

<sup>1</sup> Calcium carbonate may be used instead.

**Exp. 9. To find whether one liquid can dissolve another.**

*Required*:—Alcohol, olive oil, ether, 6 dry test-tubes.

## DIRECTIONS.

A. Take half a test-tube full of water, add a few drops of alcohol, and shake.

**Note** whether two separate layers are formed or not.

Add more and more alcohol, shaking each time.

B. Repeat A, taking a quarter of a tube full of alcohol, and adding a few drops of water.

Shake as before, and gradually fill the tube with water.

**Note** whether the mixture separates into two layers or not.

C. Repeat A and B, using water and olive oil. Keep the mixture for problem below.

D. Repeat A and B, using water and ether.

**Precaution**: The ether must on no account come near a flame.

## LABORATORY NOTES.

Observations A, B, C, and D arranged in a schedule.

*Questions*:—(i) Does water dissolve alcohol in all proportions?

(ii) Does alcohol dissolve water in all proportions?

(iii) Does water dissolve olive oil?

(iv) Does olive oil dissolve water?

(v) Does water dissolve ether in all proportions?

(vi) Does ether dissolve water in all proportions?

## PROBLEMS (VI. 9).

1. How would you attempt to separate olive oil and water? Devise some form of apparatus, and perform the experiment, if approved.

2. Knowing the boiling-points of acetone and alcohol to be respectively 55° C. and 79° C., devise a way of getting (a) pure alcohol, (b) pure acetone from a mixture of the two.

**Exp. 10. To separate a solution of two liquids by fractional distillation.**

*Required:—Distillation apparatus<sup>1</sup> with thermometer as used in Exp. 3, mixture of equal volumes of acetone and alcohol, 6 large dry test-tubes.*

#### DIRECTIONS.

**A.** Half fill the flask with the mixture, and drop in two or three pieces of clay-pipe stem. Use a test-tube as receiver. Place the bulb of the flask in a water-bath and gradually heat the water until the mixture boils.

**Note** the temperature at which boiling starts.

When the temperature has risen  $5^{\circ}$ , replace the receiver by another tube, and label the first with the range of temperature during which it was collected.

Change the receiver every  $5^{\circ}$ , and label as before.

**B.** Take the first fraction of the distillate in a smaller flask, and re-distil.

Collect the distillate in fractions as before, but between narrower limits of temperature.

**C.** Again take the first fraction and re-distil in a clean flask. Find whether you can get a distillate which is approximately pure acetone.

**D.** Take the last fraction from **A**, re-distil, rejecting the distillate below  $75^{\circ}$ .

Re-distil the last fraction once more; find whether it is approximately pure alcohol.

#### LABORATORY NOTES.

Diagram of apparatus. Scheme of various distillations, giving the approximate volumes of the distillate.

Does the first fraction in **A** contain alcohol? Give reasons.

*If so*, how do you account for its presence, since alcohol boils at  $79^{\circ}$  C.?

*If not*, how is it that the temperature rises?

<sup>1</sup> A fractionating flask of 100 c.c. capacity with exit tube sealed into the neck may be used with advantage instead of an ordinary flask.

**Exp. 11. To find whether ordinary water contains dissolved air.**

*Required:—500 c.c. flask or large tin can, trough, tubes, &c., as shown in figure.*

### DIRECTIONS.

Take the flask or tin can, and fit it up as in Fig. 27.

Fill it to the brim with tap water.

Fill the connecting tube also by sucking up water into it.

Close the end dipping into the water, and then the other end with your finger.

Press the cork into the mouth of the can and see that the apparatus is quite full of water to the end of the delivery tube.

Heat the water till it boils, collecting any gas that may escape from the delivery-tube in a test-tube standing in the trough.

If any gas is obtained, devise a means of showing whether it is air or not.

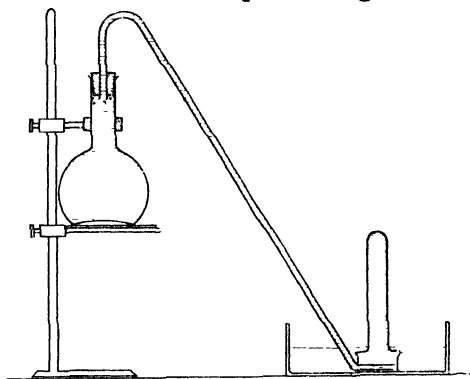

FIG. 27.

### LABORATORY NOTES.

Diagram; account of any difficulties in fitting up apparatus; observations.

*Questions:—*(i) How is it that the gas enters the test-tube? Why does it not remain at the top of the boiled water, or in the tube?

[Over

- (ii) By what tests did you find whether the gas was air or not?
- (iii) Does the solubility of a gas in a liquid increase or decrease as the temperature rises?

### PROBLEM (VI. 11).

Devise a way for finding out the volume of air dissolved by a litre of tap water at the air temperature; if approved, carry it out.

### QUESTIONS VI (b).

1. Answer any of the *preliminary questions on solution* (p. 87) which you were unable to answer or answered incorrectly before. [These should be written in your Fair Notebook after Exp. 11.]

2. By what methods may (a) suspended solids, (b) dissolved solids, be obtained free from the liquid containing them? Compare the advantages of the methods both for (a) and (b).

3. Describe and explain the use of (a) a sand-bath, (b) a water-bath, (c) an air oven.

4. Explain fully what is meant by the term *saturated solution*, and define the term *solubility of a solid*.

5. Give an account of the process of distillation, describing the various forms of apparatus employed and the method of using each.

6. Explain in detail how you would ascertain the solubility of a solid in water at 50° C.

7. How can the percentage proportions of a soluble and insoluble solid in a mixture be determined accurately?

8. What methods would you employ to separate two liquids (a) which do, (b) which do not, thoroughly mix?

9. Explain clearly and concisely what is meant by (a) Decantation, (b) Evaporation, (c) Filtration, (d) Distillation.

10. How would you find out whether coal gas dissolves in water, and if so, the volume of it which will dissolve in one litre?

## CHAPTER VII

### CRYSTALLIZATION

**Crystals.** If you have ever looked carefully at the hoar-frost on a window-pane, or the rime on trees, you will have noticed that the frozen water is arranged in beautiful and definite shapes. These are crystals of ice. You may also have noticed that snow-flakes sometimes appear to be made of crystals, but not always; and that hailstones and thick ice never appear as separate and distinct crystals.

It follows from these common observations that the formation of good crystals depends on some other conditions besides the mere act of solidification. It is because these conditions are not fulfilled that ordinary ice and the majority of minerals occur in large masses or lumps, and only rarely in well-formed crystals.

Any solids which are capable of forming into these definite geometrical shapes or crystals are called '*crystalloids*,' but there are some, such as resin and gum, which never crystallize however favourable the conditions may be; these are called *colloids* (Latin *collu*, gum), and are said to be *amorphous*, which means 'without definite shape.'

**Exp. 1. Examination and measurement of common crystals.**

*Required* :—Specimens of calcite, fluor-spar, quartz, rock salt, iron pyrites, selenite, pestle and mortar, protractor and ruler, angle measurer (see figure).

DIRECTIONS.

- A. Examine the crystals of the minerals given you.  
**Note** the shape (whether cubes, rhombs, prisms), colour, whether transparent, &c., hardness (try whether a knife will scratch it).
- B. Select three of different shapes, and draw them.
- C. Take a crystal of calcite and break it as gently as possible with a pestle in a mortar.  
**Note** whether it breaks into smaller crystals of the same shape or not.  
Try to cut one bit with a knife in different directions.  
**Note** in which directions it *cleaves* easily.
- D. Pick out two good crystals of calcite, one large, and the other small. Measure the angles of each in degrees, by means of a protractor and angle measurer, as shown in Fig. 28.

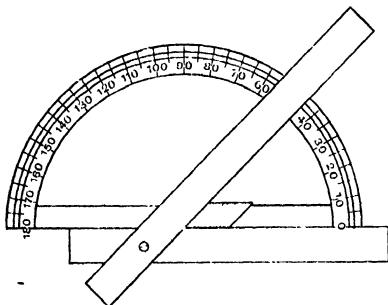

FIG. 28.



## LABORATORY NOTES.

Record your observations thus:—

Name of crystal.	Locality.	Name and sketch of shape.	Colour.	Transparency.	Hardness	Other observations.
	Say where you have previously seen a specimen	Cube, rhomb, or prism, &c.		Say whether transparent or opaque.	Say whether it is scratched by steel or not.	

Calcite.	Large crystal.	Small crystal.
1st acute angle =		
2nd „ „ =		
1st obtuse „ =		
2nd „ „ =		

- Questions:*—(i) Are all crystals transparent? Give examples.  
(ii) Are all crystals colourless?  
(iii) If a large crystal of calcite had been cut into a sphere would you say (a) that it was still a definite crystal, or (b) that it had a crystalline structure? Give reasons.  
(iv) How would you try to find out whether a rough lump of a substance was crystalline or not?  
(v) How would you test a small chip of crystal to find whether it was quartz or a bit of transparent calcite?

**Notes on the crystals examined.**

*Calcite* is very common in limestone districts, and is often called 'spar.' *Fluor-spar* occurs in veins in limestone rock, especially in Derbyshire. *Quartz* or *rock crystal* occurs in granite and in the veins of other rocks. *Rock salt* is found in crystals in the salt beds of Cheshire and Worcestershire. *Iron pyrites* is found crystallized on a large number of rocks. It occurs as a yellow film in coal. *Selenite* occurs in beds of clay, e. g. in Oxford clay.

**Exp. 2. To find out the best conditions for the formation of crystals.**

*Required:— Small flask, test-tube, evaporating basin, lens, Epsom salt, porous tile.*

#### DIRECTIONS.

- A. Take about 50 c.c. of distilled water in a small flask, and make a saturated solution of powdered Epsom salt at about  $5^{\circ}$  above the air temperature. Shake well, and finally allow the liquid to stand with excess of solid for ten minutes. Decant the clear solution into an evaporating dish. Cover with a piece of filter-paper, and leave it till next lesson in a warm place where it can evaporate slowly.
- B. Place about 30 c.c. of distilled water in an evaporating basin (labelled *X*), and make a saturated solution of Epsom salt at about  $40^{\circ}$  C. Cover with filter-paper, and allow to cool slowly. When cold, decant the liquid into another dish (labelled *Y*), and transfer the solid by means of a glass rod to a porous tile, or filter-paper, and allow to drain until dry. Select a good crystal, and make an enlarged drawing of it.
- C. Evaporate the remainder of the solution in *Y* (called the mother liquor), on a sand-bath, to half its bulk. Cool as before, and obtain a second crop of crystals. **Note** whether they are as large as the first crop;  
" " " of the same shape.
- D. Make a hot saturated solution in a test-tube. Shake vigorously, cool under the tap from time to time. **Note** whether crystals form, and compare them with those in *B* and *C* as regards size.

**A** (*continued*). Examine with a lens those obtained by the method of **A**. Compare them as regards shape and size with the others.

N. B.—Put the dried crystals in a test-tube; cork them up, label them, and keep for future experiments.

### LABORATORY NOTES.

Sketch of crystal in **B**, observations in **A**, **B**, **C**, **D**, and comparison of crystals with regard to size.

*Questions*:—(i) Do the largest crystals form when (*a*) the solution is cooled quickly or slowly; (*b*) the solution is agitated or still?

(ii) Why are no crystals formed from a cold *unsaturated* solution which is kept corked up? Give reasons.

(iii) Would crystals form from a cold *saturated* solution which is kept corked up? Give reasons.

(iv) What do you think would be the best way of growing a very large crystal?

### PROBLEM (VII. 2).

Obtain and draw a good crystal of one or more of the following powdered substances:—*Blue vitriol, white vitriol, alum, nitre, Glauber's salt, common salt.*

#### **Exp. 3. To grow a large crystal.**

*Required*:—*Powdered alum or blue vitriol, 4 oz. flask, 2 beakers, funnel.*

### DIRECTIONS.

Make a *saturated* solution of alum or blue vitriol at about 25° C. or 30° C. Filter the solution into a clean beaker; label it, cover with paper to exclude dust, allow to cool slowly, and when a few crystals have formed, pour the clear liquid into another clean beaker.

Drop into this the best crystal, and allow the whole to stand for some days.

Turn the crystal over occasionally, so as to expose all sides to the solution.

Take out any smaller ones which form.

### LABORATORY NOTES.

Description of the process at the different stages.

*Questions*:—(i) How did you ensure that your solution was saturated?

(ii) Supposing it was saturated, are you sure to find crystals after a day or two? State any conditions which might prevent their formation.

### PROBLEM (VII. 3).

Grow a large crystal as in Exp. 3, but suspend a small piece of glass rod by a thread in the clear warm solution. Leave a good crystal on this for the second beaker and grow the large one round it. Use *bichromate of potassium*.

**Conditions of Crystallization.** Exp. 2 will have shown that the best crystals form when a saturated solution is allowed to cool and evaporate very slowly without shaking. This is because the solid which gradually comes out of solution as evaporation proceeds will develop itself on a crystal already formed, so increasing its size, rather than form an independent crystal. Shaking and rapid evaporation or sudden cooling prevent this.

If a hot saturated solution is kept quite still and cooled very slowly, it sometimes does not crystallize until it is shaken or a small crystal of the solid dropped in. Such a solution is said to be *super-saturated*: the solution of 'hypo' after cooling in Exp. 5, p. 56, is an example.

**Exp. 4. To find the effect of heat on certain crystals.**

*Required:—Hard glass tube 8" ×  $\frac{5}{8}$ " diam., cork and exit tube, boiling tube, conical flask, retort-stand, crystals of blue vitriol, gauze, watch-glass, thermometer, balance, 6 test-tubes, absolute alcohol, turpentine.*

**DIRECTIONS.**

A. Take about 25 to 30 g. of the *small* crystals of blue vitriol. See that they are quite dry. (If wet, press them between layers of filter-paper.)

Put them in a dry tube, and arrange as shown in Fig. 29.

[If the tube is of thick glass, wrap it with one layer of wire gauze.]

Heat the blue solid with a small flame, carefully moving it to and fro along the tube, but *avoid* burning the cork.

**Note** all that happens, and record it in the proper order.

Keep the whole tube warm till all action seems to be over. Detach the tube, and examine the solid to see whether it is still crystalline.

[Cork up this solid in a small tube, label, and keep it.]

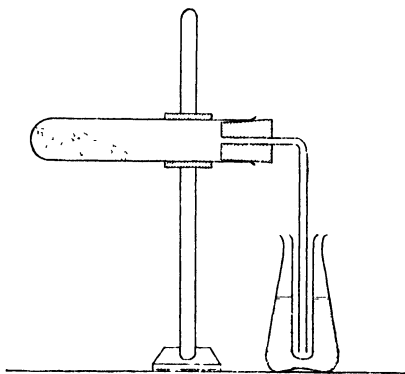

FIG. 29.

*B. Try to identify the liquid in the boiling tube.*

1st. **Note** its colour and smell (if any); see whether it flows about readily (i. e. whether it is *mobile*, like ether, water, or alcohol) or whether it is *viscous* (like olive oil or treacle).

2nd. Put a drop on a clean watch-glass, and carefully evaporate to dryness.

**Note** whether any residue is left or not.

3rd. Find its boiling-point<sup>1</sup> (see Exp. 7, p. 59).

**Note** whether it boils at a constant temperature or not.

Keep as much liquid as possible for the next experiment.

4th. Find its density, using the most suitable method for a small quantity (see p. 81).

Do not use less than 5 c.c.

*C. Take half the solid residue from A from the corked tube, and place a little in each of five dry test-tubes, and a little in a watch-glass.*

Add a few drops of water to No. 1; pure alcohol to No. 2; alcohol mixed with water to No. 3; turpentine to No. 4; some of the liquid used in *B* to No. 5.

**Note** the effect in each case.

Leave the watch-glass with the powder in your cupboard till next lesson, and then observe the result.

### LABORATORY NOTES.

Diagram *A* and full account of observations *A*, *B*, and *C*.

*Questions*:—(i) What do you think the liquid is? Give reasons.

(ii) Is it a pure liquid or a mixture?

(iii) If you dissolved the solid residue from *A* in water and evaporated slowly, would you expect to get crystals again?

<sup>1</sup> In case the quantity of liquid is very small, two or three pupils should combine for this and the following tests.

- (iv) If so, do you expect them to be the same as those you started with, or different? [If in doubt, try it.]
- (v) For the detection of what liquid can the white residue be used?

### PROBLEM (VII. 4).

Repeat Exp. 3, using either *washing soda*, *white vitriol*, *alum*, or *Glauber's salt*, but avoid heating them too strongly. Identify the liquid in each case.

### Exp. 5. The effect of heat on other crystals.

*Required*:—*Small ignition tubes, crystals of common salt, nitre, iodine, sal-ammoniac, lens.*

### DIRECTIONS.

- A. Use a few dry crystals of common salt or of nitre.  
Heat in a dry tube (holding it in a sloping direction) in a small Bunsen flame.
- Note** (a) whether the solid decrepitates (i. e. breaks up violently, causing particles to fly off);  
(b) whether the solid melts, and if so, what happens to the liquid;  
(c) whether any liquid deposits in the cool part of the tube.
- B. Use crystals of iodine or sal-ammoniac.  
**Note** whether it melts, gives off a liquid or vapour.  
Examine the deposit with a lens—breaking the tube if necessary.

### LABORATORY NOTES.

Observations *A* and *B*.

- Questions*:—(i) Do all crystals give up water on heating?  
(ii) Arrange the crystals you have heated in Exps. 4 and 5 in three classes according to the effect of heat upon them.

[Over

## PROBLEM (VII. 5).

Devise a means of separating a mixture of salt and sal-ammoniac, without using a liquid.

Carry out your method, when approved.

**Water of Crystallization.** From Exps. 4 and 5 you will have seen that some crystals yield water on heating, while others do not. This water is called 'water of crystallization'; many solids will not crystallize unless water is present, and if they do, the crystals are of a different shape. Some solids form crystals of more than one shape, depending on the amount of water of crystallization.

Substances like common salt, nitre, and iodine, which contain no water of crystallization, are said to be '*anhydrous*'—a word derived from Greek, meaning 'without water.'

**Volatility.** On heating iodine or sal-ammoniac you will have observed that they do not melt (or melt only partially), but are turned almost at once into vapour, which condenses again in crystals on the cool part of the tube. The conversion of a solid into a vapour directly by heat, with subsequent collection of the re-formed solid, is called *sublimation*. The condensed vapour is called a *sublimate*, and a solid capable of undergoing sublimation is said to be *volatile*—a term also applicable to liquids of low boiling-points. Ordinary 'smelling salts' is an example of a volatile solid, and is called *sal-volatile*; camphor also vaporizes without previous melting.



**Exp. 6.** To find the percentage weight of liquid formed by heating certain crystals.

*Required:—Pestle and mortar, crucible (size 00), pipe-clay triangle, retort-stand, balance, blue vitriol or Epsom salt.*

#### DIRECTIONS.

A. Use crystals of Epsom salt or blue vitriol.

Pound up a small quantity in a clean mortar.

*Half* fill a weighed porcelain crucible with the powder.

Weigh the crucible with powder and lid. Now place it on a pipe-clay triangle resting on the ring of a retort-stand.

Heat with a small flame at first, and then with a larger one.

Hold the lid with tongs just over the crucible, and watch what happens.

Continue heating for about 15 min. (The lid may be replaced so as not to cover the crucible entirely.)

Allow to cool (with the lid on) and weigh when quite cold.

B. Heat again for 5 min. as before, cool, and weigh again.

**Note** whether there is any further loss in weight. (If so, continue till two consecutive weighings agree.)

#### LABORATORY NOTES.

Diagram, observations, and scheme of weighings for A and B.

Calculate what weight of water 100 g. of blue vitriol would lose on heating.

*Questions:—*(i) Why were the crystals first broken up in a mortar?

(ii) In B why had you to re-heat until two consecutive weighings were the same?

(iii) Are the contents of the crucible liable to increase in weight while cooling?

#### PROBLEMS (VII. 6).

1. Find the percentage weight of water of crystallization in (a) *soda crystals*, (b) *gypsum*, or (c) *white vitriol*.

2. Find the percentage weight of salt in a *mixture of salt and sal-ammoniac*.

**Exp. 7. To separate a mixture of two soluble solids.**

*Required* :—2 flasks (150 c.c.), powdered blue vitriol and alum, rough balance, test-tube, funnel.

## DIRECTIONS.

Mix about 5 g. of powdered blue vitriol with about 50 g. of powdered alum.

Place in a flask, and add about 75 c.c. of distilled water.

Heat the mixture until a solution is obtained.

Cool rapidly under the tap, and shake the flask.

Filter and collect the filtrate in another flask.

When the filtrate has collected, pour a test-tube full of cold distilled water gradually on to the filter-paper and residue.

Let this pass through before adding more.

Repeat the washing as long as the residue remains blue.

This method of separation is known as *fractional crystallization*.

## LABORATORY NOTES.

## Observations.

*Questions*:—(i) What is the colour and name of the substance forming (a) the residue, (b) the filtrate?

(ii) What was the reason for washing the residue?

(iii) Would you expect to find any alum in the filtrate?

(iv) How do you explain the fact that pure alum has been obtained, seeing that both the solids are soluble in water?

## PROBLEMS (VII. 7).

1. Devise a way of getting a pure specimen of the blue crystals. Carry it out, if approved.

2. Try to separate a mixture of 30 g. of chlorate of potash with 10 g. of chromate of potash.

**Exp. 8. To find the effect of exposing certain crystals to the air.**

*Required:—3 watch-glasses, good dry crystals of washing soda, blue vitriol, magnesium chloride, balance.*

#### DIRECTIONS.

A. Select a few good dry crystals of (a) washing soda, (b) blue vitriol, (c) magnesium chloride.

Label three watch-glasses, and place one kind of crystal on each.

Weigh each with its crystal, and write the weight on the label.

Put them aside till the next lesson, screening them from dust.

B. Note any change in appearance of the crystals. Re-weigh each.

**Note** any change in weight.

#### LABORATORY NOTES.

Weighings in A.

Observations and weighings in B.

*Questions:—*(i) Knowing that washing soda gives up water on heating, what do you think happened on leaving it in air?

(ii) What do you think has happened to the magnesium chloride?

(iii) How could you test the truth of your answer to (ii)? Try it, if approved.

#### PROBLEM (VII. 8).

Find the effect of exposing lumps of *calcium chloride, caustic soda, sodium sulphate, and alum* to the air for three or four days.

### Efflorescence and Deliquescence.

When a solid gives off its water of crystallization on exposure to the air at the ordinary temperature, it is said to '*effloresce*.' Exp. 8 will have shown that washing soda crystals are efflorescent.

On the other hand, some solids (whether crystalline or not) absorb moisture from the air, and then dissolve in the water they have attracted. These are said to '*deliquesce*' in air or to be deliquescent solids. Both classes of substances should always be kept in closely stoppered bottles.

Advantage is taken of the action of deliquescent bodies

in moist air in order to provide a dry atmosphere in which a body liable to absorb moisture can be kept dry. An arrangement of this kind, shown in Fig. 30, is called a desiccator (to '*desiccate*' means to '*dry*').

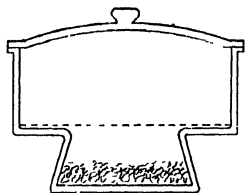

FIG. 30.

A layer of some very deliquescent substance, such as calcium chloride (called a desiccating agent), is placed in the bottom of the circular glass vessel. Above this is a perforated zinc shelf on which the object to be kept dry is placed (Fig. 30).

The whole is closed with a glass lid with a ground rim, which, when greased, fits tightly over the desiccator. Substances like those used in Exp. 6 should be cooled in it. All the moisture in the air inside the vessel is absorbed by the desiccating agent, so that the substance cannot absorb any, and is thus prevented from increasing in weight.

**Exp. 9. To form crystals by cooling a melted solid.**

*Required:—Crucible (size 00) or other vessel used for melting sulphur, flowers of sulphur, tripod, pipe-clay triangle, beaker.*

**DIRECTIONS.**

Place the crucible securely on a pipe-clay triangle resting on a tripod, and half fill with flowers of sulphur. Heat gently until melted, adding more solid until the vessel is about two-thirds full of liquid.

**Note** the changes in colour and mobility.

**Precaution:** Avoid setting fire to the liquid. (If it lights, remove the lamp, and extinguish the flame by covering the crucible with a lid.)

Heat for two or three minutes after complete liquefaction, and then allow to cool.

Watch the process of solidification, and when a solid crust has formed on the top, make a hole in it with a glass rod.

Quickly pour out the remaining liquid into some water in a beaker.

Allow the crucible to become quite cool, and remove any crust on the top.

**Note** the appearance of the solids in the crucible and beaker.

**LABORATORY NOTES.**

Diagram of apparatus; description and observations.

*Questions:—*(i) Why was some of the liquid poured out of the crucible?

(ii) What is the shape and colour of the crystals?

(iii) Compare the shape of the crystals with those obtained in the Problem on p. 97. [If you have not done this do it now. No flame must be near.]

(iv) What are the two chief ways of obtaining crystals?

(v) Did the liquid sulphur which was poured into cold water crystallize? Account for the result.

(vi) State your reasons for thinking that sulphur crystals do, or do not, contain water of crystallization.

## QUESTIONS ON CHAPTER VII.

1. Explain as clearly as possible what you understand by the term '*crystal*.' Mention three crystalline substances and give a sketch of the shape of the crystals.

2. Give an account of the best conditions for crystallizing a solid from its solution so as to obtain a well-formed crystal.

3. Natural crystals are generally found in the cavities of rocks, not in the solid mass. Account for this.

4. What is a saturated solution? What thermal effect is noticeable when crystallization takes place from such a solution?

5. Would you expect the thermal effect of Question 4 (*a*) to occur, (*b*) to be easy to observe, when crystallization takes place slowly? Give reasons.

6. By what means would you ascertain whether a given liquid (*a*) contains water, (*b*) is pure water?

7. What is the meaning of the terms, 'water of crystallization,' 'decrepitation,' 'sublimation,' 'volatility'?

8. Describe a method of determining the percentage of water of crystallization in a solid, mentioning all the precautions necessary to ensure an accurate result.

9. 1.68 g. of a crystalline solid weighed 1.07 g. after heating. Calculate the percentage weight of water of crystallization.

10. The solubilities of nitre and salt at 0° C. are 12 and 36 respectively, and at 100° C., 247 and 38. How would you obtain a pure specimen of nitre from a mixture of equal weights of the two substances?

11. How can you find the proportions by weight in which a volatile and a non-volatile solid have been mixed? Give details.

12. Define the terms 'deliquescence' and 'efflorescence,' and give examples of deliquescent and efflorescent bodies.

13. Explain the construction and use of a desiccator.

14. How can crystals of certain solids be obtained without first dissolving them? Are the conditions for obtaining good crystals the same as those asked for in Question 2? Give reasons.

15. Explain the details of the method of obtaining a pure specimen of a solid from a mixture, by fractional crystallization.

## CHAPTER VIII

### SOME PROPERTIES OF AIR

#### **Preliminary Questions on Air.**

[*These are to be answered in your Fair Notebook as explained on p. 87.*]

1. Name the three groups into which materials can be classified. Give one example of each group.

2. What are the chief differences between (a) solids and liquids, (b) liquids and gases? [Write your answer in *general* terms, and if you give examples, be sure that they are typical.]

3. Name three distinct observations you have made which lead you to believe in the existence of air.

4. How could you show that a so-called 'empty' flask contains air? What is meant by the word 'vacuum'?

5. What is the meaning of the word '*atmosphere*'? Does it mean the same as the word '*air*'? Explain the difference, if any.

6. Explain the meaning of '*fluid*,' and contrast it with '*liquid*.'

7. Name any other substances you have come across which you would put in the same class as air?

8. How would you arrange an experiment to find out if air expands on heating?

9. What do you understand by the common statement—'The pressure of the atmosphere is  $14\frac{1}{2}$  lb. to the square inch'?

10. How could you find out if air can easily be compressed?

11. What is the meaning of the word 'property' in the title of this chapter? Make a list of the properties of air as far as you know them and state its chief functions.

**Exp. 1. To find out if air has weight.**

*Required:—Balance, flask 250 c.c. capacity (or larger if the balance will take it), good cork, glass and rubber tubes, spring clip, measuring jar, beaker of water.*

## DIRECTIONS.

## A. Fit up the flask as shown in Fig. 31.

Be careful that the cork and tube fit tightly.

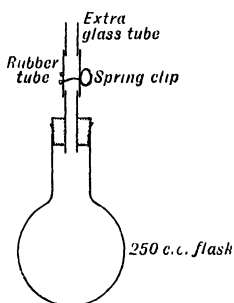

FIG. 31.

Weigh the flask with the tubes and clip in position. (Use the rider.)

**Record** the weight.

Temporarily connect a second glass tube to the rubber above the clip.

Through this tube suck out as much air as possible, closing the clip immediately<sup>1</sup>.

**Precaution:—***Avoid letting saliva get into the permanent tubes or flask.*

Remove the extra glass tube, and weigh again, being careful to avoid draughts.

**Record** the weight.

B. Invert the neck of the flask in water, and open the clip. [Hold the flask by the neck—not the bulb.]

**Note** what happens.

Close the clip again, and place the flask upright.

Pour the water from the flask into a measuring glass.

**Note** the volume of water very accurately.

<sup>1</sup> If a Bunsen water-pump is available, air may be sucked from the flask by its use instead of by the method described above.



## LABORATORY NOTES.

Draw a diagram of the apparatus used and record weighings thus:—

Weight of flask, &c., full of air	.	.	=	g.
" " with some air withdrawn			=	g.
				_____
Weight of air withdrawn			=	g.
				_____

Volume of water = volume of air withdrawn = c.c.

Calculate (a) the density of air relative to water,

(b) the weight of 1 litre of air.

- Questions*:—(i) Why is it so necessary to avoid draughts when weighing?
- (ii) Besides errors of weighing, what other errors are liable to be made? State whether they would make your result too large or too small. [The errors in this experiment are relatively large.]
- (iii) What fraction of the total air in the flask were you able to draw out?
- (iv) (a) How could you proceed to find the weight of *all* the air in the flask? (b) If you displaced the air in the flask by coal gas and then weighed it, how could you find the weight of 1 litre of coal gas without sucking out any of the gas?
- (v) If a small rubber balloon were weighed (a) full of air, (b) without air inside, would any difference be observed? Give reasons.
- (vi) Knowing that a solid weighs less in water than in air, do you think the weight in air would be different from the weight in a vacuum? Give reasons.

## PROBLEMS (VIII. 1).

1. Devise a means of finding whether air expands on heating. Carry it out, if approved.
2. Find the weight of a litre of coal gas. [Be careful to avoid bringing the gas near a flame.]

**Exp. 2.** To measure the expansion of air between  $0^{\circ}\text{C}$ . and  $100^{\circ}\text{C}$ .

*Required*:—Narrow tube attached to scale and containing a pellet of mercury as in Fig. 32, thermometer, ice, beaker on stand.

#### DIRECTIONS.

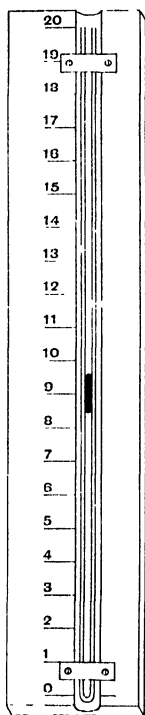

Fig. 32.

Place the tube with its scale in a beaker of water, and add small lumps of ice.

Stir with a thermometer until the temperature is reduced to  $0^{\circ}\text{C}$ .

Tap the tube to enable the pellet of mercury to take up its proper position.

**Note** the volume<sup>1</sup> of the air and the temperature.

Gradually heat the contents of the beaker to about  $10^{\circ}\text{C}$ .

Remove the lamp, and stir vigorously for two minutes.

**Note** the volume of air and the exact temperature.

Repeat this for intervals of  $10^{\circ}\text{C}$ . up to  $100^{\circ}\text{C}$ .

#### LABORATORY NOTES.

Record the volumes and temperatures in two columns and plot the results on squared paper, making the abscissae<sup>2</sup> represent temperatures and ordinates volumes.

Expansion is measured by the increase in volume sustained by unit volume at  $0^{\circ}\text{C}$ . when heated through  $1^{\circ}\text{C}$ .

<sup>1</sup> The volume of the air in the tube = area of cross-section  $\times$  length. As the area of cross-section is the same at different parts of the tube, the volumes are proportional to the lengths as read off from the scale.

<sup>2</sup> In Fig. 26, p. 102, the abscissa of the point  $p$  is  $B_y$ , the ordinate of  $p$  is  $py$ .

Calculate as follows:—

$$\begin{array}{l} \text{Volume at } 0^{\circ} \text{ C.} \quad . \quad . \quad = a \times k \text{ (where } k \text{ is area of} \\ \text{,, ,, } 100^{\circ} \text{ C.} \quad . \quad = \overline{b \times k} \quad \text{cross-section)} \end{array}$$

$$\therefore \text{increase in vol. between } 0^{\circ} \text{ and } 100^{\circ} = \overline{(b - a) k}.$$

$$\begin{aligned} \therefore \text{increase in volume (for } a k \text{ units of vol. at } 0^{\circ} \text{ C.) for } 1^{\circ} \text{ C.} \\ = \frac{(b - a) k}{100}. \end{aligned}$$

$$\begin{aligned} \therefore \text{increase in volume of unit vol. at } 0^{\circ} \text{ C. for } 1^{\circ} \text{ C. rise} \\ = \frac{(b - a) k}{a \times k \times 100} = \frac{(b - a)}{100 a}. \end{aligned}$$

Express the result both in vulgar and decimal fractions.

*Charles's Law.* Very accurate experiments on the expansion of air have shown that 1 c.c. at  $0^{\circ}$  C. becomes  $1\frac{1}{273}$  c.c. at  $1^{\circ}$  C. This increase in volume undergone by unit volume of air at  $0^{\circ}$  C., when heated through  $1^{\circ}$  C., is called the '*coefficient of expansion*' of air. The numerical value of the coefficient is  $\frac{1}{273}$  or .00366.

It has also been found that *all* gases have the same coefficient of expansion, and this fact is comprised in the generalization (or general statement) known usually as **Charles's Law**—though it is sometimes ascribed to Dalton, and also to Gay-Lussac.

The law may be expressed as follows:—

*The volume of a given mass of any gas at  $0^{\circ}$  C. increases by  $\frac{1}{273}$  of this volume for every degree centigrade through which it is heated; conversely, the volume decreases by  $\frac{1}{273}$  of its volume at  $0^{\circ}$  C. for every degree centigrade through which the gas is cooled, the pressure being supposed to remain constant.*

Suppose a flask had a capacity of 273 c.c., and that it contained as before air at  $0^{\circ}$  C. On being heated from—

$0^{\circ}$  C. to  $1^{\circ}$  C. its volume increases by  $\frac{1}{273}$  of 273 c.c., i. e. by 1 c.c. 273 c.c. at  $0^{\circ}$  C. become  $(273 + 1)$  c.c. at  $1^{\circ}$  C.

„ „  $(273 + 10)$  c.c. at  $10^{\circ}$  C.

„ „  $(273 + 100)$  c.c. at  $100^{\circ}$  C.

„ „  $(273 + 273)$  c.c. at  $273^{\circ}$  C.

i. e. the volume is doubled at  $273^{\circ}$  C.

If cooled below  $0^{\circ}$  C. the volume decreases by  $\frac{1}{273}$  of the volume at  $0^{\circ}$  C.

Thus 273 c.c. at  $0^{\circ}$  become  $(273 - 1)$  c.c. at  $-1^{\circ}$  C.

„ „  $(273 - 10)$  c.c. at  $-10^{\circ}$  C.

„ „  $(273 - 273)$  c.c. at  $-273^{\circ}$  C.

i. e. the volume is reduced to 0.

The volume of a gas never can be reduced to zero, because before this temperature is reached, the gas becomes a liquid or solid; in fact no gas obeys Charles's Law for *very low* temperatures.

Since  $-273^{\circ}\text{C}$ . is the temperature at which a gas should theoretically occupy no volume at all, it is sometimes called Absolute Zero or  $0^{\circ}\text{A}$ .

$$\begin{aligned}\text{Thus } 0^{\circ}\text{A.} &= -273^{\circ}\text{C.} \\ 10^{\circ}\text{A.} &= -263^{\circ}\text{C.} \\ 273^{\circ}\text{A.} &= 0^{\circ}\text{C., \&c.,}\end{aligned}$$

and the scale is called the Absolute Scale of temperature.

In calculating the influence of temperature on the volumes of gases it is convenient to make use of the absolute scale, and so avoid the necessity for first reducing the volume of a gas to  $0^{\circ}\text{C}$ .

Thus, to calculate the new volume after 15 c.c. of air at  $10^{\circ}\text{C}$ . have been heated to  $20^{\circ}\text{C}$ . :—

First change the C. degrees to A. degrees—

$$10^{\circ}\text{C.} = (10 + 273)^{\circ}\text{A.} = 283^{\circ}\text{A.}$$

$$20^{\circ}\text{C.} = (20 + 273)^{\circ}\text{A.} = 293^{\circ}\text{A.}$$

At  $283^{\circ}\text{A}$ . the volume is 15 c.c.

$$,, \quad 1^{\circ}\text{A.} \quad ,, \quad ,, \quad \frac{15}{283} \text{ c.c.}$$

$$,, \quad 293^{\circ}\text{A.} \quad ,, \quad ,, \quad \frac{15 \times 293}{283} \text{ c.c.}$$

Charles's Law may be stated in the following convenient form :—

*The volume of a given mass of any gas varies directly as its absolute temperature, provided that the pressure is constant.*

If  $V$  be the volume of a given mass of gas and  $T$  its absolute temperature, the law states that  $V \propto T$ .

By algebra  $V = kT$  or  $\frac{V}{T} = k$  (i),

where  $k$  is some constant depending on the particular mass of gas used.

If  $V$  changes to  $V'$  owing to  $T$  changing to  $T'$ ,

$$\text{then} \quad V' = kT' \text{ or } \frac{V'}{T'} = k \text{ (ii).}$$

Since  $\frac{V}{T}$  and  $\frac{V'}{T'}$  are both equal to  $k$ ,  $\frac{V}{T} = \frac{V'}{T'}$ , which is a useful symbolical statement of the law.

## EXAMPLES VIII (a).

1. Express  $15^{\circ}\text{C}$ .,  $-15^{\circ}\text{C}$ .,  $0^{\circ}\text{C}$ .,  $273^{\circ}\text{C}$ .,  $-273^{\circ}\text{C}$ . in degrees absolute.
2. If some air occupies 117 c.c. at  $17^{\circ}\text{C}$ ., what space will it occupy at  $0^{\circ}\text{C}$ . ?
3. A gasometer of 6,000 c.m. capacity is half filled with coal gas at  $15^{\circ}\text{C}$ . What volume will the gas occupy when the sun has raised its temperature to  $20^{\circ}\text{C}$ . ?
4. Some air at  $-10^{\circ}\text{C}$ . is heated to  $+10^{\circ}\text{C}$ ., at which temperature it occupies 1 litre. What was the volume at  $-10^{\circ}\text{C}$ . ?
5. What is the density of air at  $273^{\circ}\text{C}$ . relative to that at  $0^{\circ}\text{C}$ . ?
6. If the specific gravity of air at  $0^{\circ}\text{C}$ . be taken as 1, at what temperature will it have a specific gravity of  $\cdot 75$  ?
7. If a litre of air at  $0^{\circ}\text{C}$ . weighs 1.29 g., how many cubic centimetres will 1 g. of air occupy? and what will be the weight of 1 c.c. ?
8. A room measures 8 m. long, 5 m. broad, and 3 m. high. What weight of air will it hold at  $0^{\circ}\text{C}$ . ?
9. What volume of air at  $15^{\circ}\text{C}$ . will escape from a litre flask as its temperature rises from  $0^{\circ}\text{C}$ . to  $15^{\circ}\text{C}$ . ? What weight of air will the flask contain at  $15^{\circ}\text{C}$ . ? (For the weight of a litre of air at  $0^{\circ}\text{C}$ . see Question 7.)
10. Describe how the mass of a litre of air may be found.
11. A body occupying 250 c.c. is weighed in air and found to have a mass of 73.682 g. Find its true mass, taking the mass of 1 litre of air at the temperature of the room as 1.292 g.
12. Explain fully how Charles's Law may be verified.

**Exp. 3.** To show that air can (a) be compressed, (b) exert pressure.

*Required:*— Test-tube, gas-jar, and glass cover-plate.

#### DIRECTIONS.

A. Push an inverted test-tube straight down, an inch or two at a time, into a gas-jar nearly filled with water.

**Note** (a) whether any water enters the tube.

Slowly raise the tube until it is near the top of the water.

**Note** (b) whether the air now occupies the whole tube or not.

B. Fill the gas-jar with water, and cover it with a ground-glass plate.

Keep the cover in position with your fingers, invert the jar, and then remove your fingers from the plate.

C. Repeat B with the jar half full of water, inverting it over a sink containing water.

**Note** (c) what happens in each case.

#### LABORATORY NOTES.

Observations (a), (b), and (c).

*Questions:*—(i) What does observation (a) prove?

(ii) The result of (a) might be explained by saying that the air dissolved in the water. How do you know that this is incorrect?

(iii) Explain why the plate and water behind it do not fall down in B, but do so in C.

(iv) Does the compression of the air in A depend on the depth to which the tube is pushed down into the water? Give reasons.

(v) If B were constantly repeated with longer and longer tubes do you think the result would always be the same, or would a limit in the length be reached when the cover and water would fall? Give reasons.

**Exp. 4. To measure the pressure of the atmosphere.**

*Required:—Thick-walled glass tube 100 cm. long, sealed at one end; funnel, dry mercury, trough, tray, clamp on stand, metre scale.*

**DIRECTIONS.**

Clamp the tube with the open end uppermost, and place it in the tray. By means of a funnel fill the tube with mercury to within 3 cm. of the top. Unclamp the tube, and, after closing the open end with your thumb, invert it two or three times to collect the minute air bubbles which adhere to the glass into one large bubble.

Clamp the tube again, and completely fill it, and carefully invert it into a trough of mercury. **Note** what happens in the tube.

Gradually slope the tube; **note** again what happens.

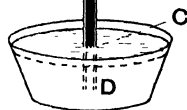

FIG. 33.

Finally clamp the tube vertically, and measure the height of the surface of the mercury in the tube above that in the trough.

**LABORATORY NOTES.**

Record all your observations carefully and draw a diagram.

**Questions:—**(i) Will the atmosphere support a column of mercury 100 cm. long?

(ii) What is the measure of the atmospheric pressure reckoned by the height of the mercury column?

(iii) Why is the measurement of the column of mercury supported by the atmosphere, taken as *BC* (Fig. 33) and not *BD*?



- (iv) Is there any air in  $AB$ ? Give reasons.
- (v) Taking the sp. g. of mercury at 13.6, calculate the maximum length of a column of water that would be supported by atmospheric pressure.
- (vi) Explain why the mercury fills the tube when sufficiently inclined from the vertical.

**The Barometer.** The instrument made in the last experiment, and shown in Fig. 33, is the simplest form of a barometer—a word derived from Greek, meaning *pressure-measure*.

The space  $AB$  contains nothing, and is called a *vacuum*—the Latin for ‘empty space’—or sometimes a Torricellian vacuum, after an Italian named Torricelli who first made a barometer. Inside the tube is the column of mercury  $BD$  pressing downwards. The portion  $CD$  is balanced by the pressure of the mercury in the trough, so that the atmospheric pressure balances the remainder  $BC$ .

A barometer may be considered as one limb of a U-tube, the other imaginary limb extending from the trough upwards as far as the atmosphere reaches. The weight of the column of air in this imaginary limb, which is several miles long, balances the short column of mercury in the closed glass tube. Two barometers at the foot of a mountain would indicate the same pressure, but if one is carried to the top the mercury column diminishes in length, since the column of air in the imaginary limb is now shorter. The variations in the barometric height at a given place are due to alterations in the density of the column of air above the place. The density changes with change of temperature, and this causes currents of air or winds. If there were no air currents the barometric height at a given place would always be the same. The average height at sea-level is 760 mm. (about 30 inches), but the higher the place is above the sea, the lower is the barometric height.

The simple type of barometer made in Exp. 4 is too

inconvenient for ordinary use, since it has not a fixed scale. Now a fixed scale would be useless unless the zero was always at the level of the mercury in the trough, but this level is lowered when that in the tube rises, and *vice versa*.

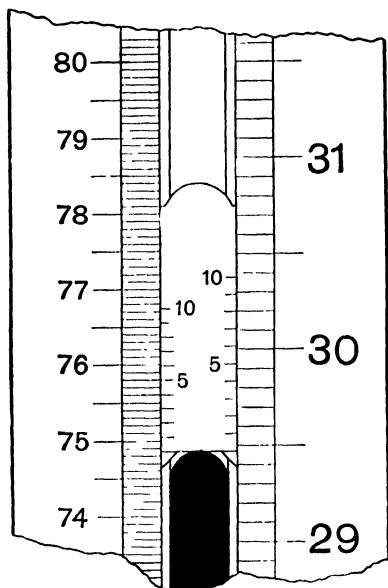

FIG. 34.

The difficulty is overcome in the best barometers (e.g. Fortin's barometer) by having the trough or cistern partly made of leather, which can be pushed up or let down by means of a screw so as to bring the level of the mercury to the zero of the scale. This is usually indicated by an ivory point fastened to the cover of the glass cistern, so that by turning the screw the mercury can

be adjusted so as to touch the point before a reading is taken.

To increase the accuracy of the scale readings, a vernier is attached, as shown in Fig. 34.

**Exp. 5. To read the barometric height on a Fortin's barometer.**

Adjust the screw carefully till the ivory point seems to meet its reflection in the mercury.

Make out the construction of the verniers, and then adjust the lower edge of the vernier until it is a tangent to the meniscus.

Take the reading both in centimetres and inches.

Draw a careful diagram of the whole instrument.

**Exp. 6.** To find the pressure required to halve the volume of a given mass of air.

*Required:—Mercury and tray, J-tube as in Fig. 35, clamp and stand, metre scale, small funnel.*

### DIRECTIONS.

Take a narrow glass tube about 120 cm. long and seal one end.

Bend it into a J-tube, the short limb being about 20 cm. long, and having its end sealed at *C* (Fig. 35).

Place a small funnel at the open end, and pour in enough mercury to fill the bend.

Slope the tube to let some air escape from the short limb until the level of the mercury in each limb is the same.

Clamp the tube in a vertical position over a tray, and place a piece of gummed paper to mark the position of *B*.

By means of a metre rule measure very carefully the vertical height of *B* and *C* above the tray (or base of retort-stand), and by subtraction find the length of *BC*, and place a piece of paper to mark the middle point (*E*) of *BC*.

Read the barometer.

Pour in more mercury until the level in the short limb is at *E*.

Measure the heights of the mercury levels *E* and *F* above the tray, and find the difference.

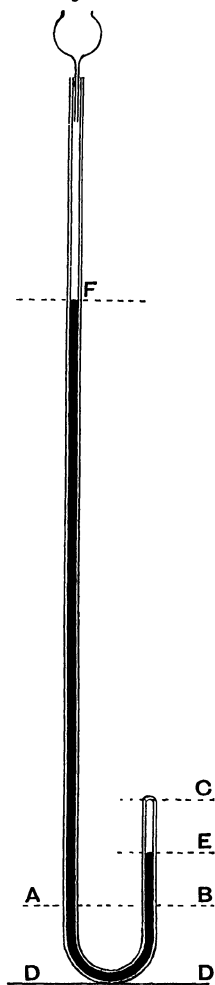

Fig. 35.

[Over

## LABORATORY NOTES.

Diagram of apparatus.

Record of measurements thus:—

Height of  $C$  above tray ( $D$ ) . . . = mm.

„  $B$  „ „ . . . = mm.

∴ length of  $BC$  . . . = mm.

Height of  $F$  above tray ( $D$ ) . . . = mm.

„  $E$  „ „ . . . = mm.

∴ difference in level between  $E$  and  $F$  = mm. (X)

Height of barometer = mm. ( $Y$ )

Pressure required to halve the volume of air used is that due to a column of mercury  $X + Y$  mm. high.

*Questions*:—(i) Explain why the pressure acting on the air at the end of the experiment is expressed as  $X + Y$  mm.; why not  $X$  alone?

(ii) What was the pressure on the air in  $BC$  at the beginning of the experiment?

(iii) As the tube is cylindrical the volumes of air in  $BC$  and  $EC$  are proportional to the lengths  $BC$  and  $EC$ . Multiply these lengths by the respective pressures and compare the two results.

**Exp. 7.** To find the relation between the pressure and volume of a given mass of air.

*Required*:—Apparatus as in the last experiment.

### DIRECTIONS.

Arrange the tube (Fig. 35) as at the beginning of the last experiment, having the levels (*A* and *B*) the same in each limb.

Measure the heights of *B* and *C* above the tray, and read the barometer.

The distances from *C* to the levels in the short limb are proportional to the volumes of air in this limb.

Pour mercury into the long tube till about  $\frac{1}{3}$  full.

Measure the levels above the tray.

Add a little more mercury and take similar readings, and repeat at least twice more.

### LABORATORY NOTES.

Volume of air.	Pressure.	Vol. $\times$ press.
(1) $(CD - BD) =$	760 mm. <sup>1</sup>	$(CD - BD) \times 760^1 =$
(2) &c.	760 + ... mm.	

Plot a curve for the relation between the volume and pressure, making volumes the abscissae and the pressures the ordinates.

**Questions**:—(i) What conclusion do you draw from the results in the third column ( $V \times P$ )?

(ii) What are the chief sources of error connected with the experiment?

<sup>1</sup> Substitute the actual barometer reading.

## PROBLEM (VIII. 7).

Find whether the relation between the volume and pressure holds good when the pressure is less than one atmosphere. [Use the same apparatus as in Exp. 6, but make the mercury fill three-fourths of closed limb, and only just come a little way up the open limb. Find the volume and pressure. Gradually add more mercury, and find volume and pressure each time. Stop when the level of the mercury in both tubes is the same. Plot another curve.]

**Boyle's Law.** Exp. 6 has shown that when the pressure is doubled the volume is halved. Exp. 7 shows that, for the same mass of air, the product obtained by multiplying the pressure by the volume is approximately constant. This is also expressed by saying that the volume is inversely proportional to the pressure.

These facts with regard to the effect of pressure on a given mass of air were first discovered by Robert Boyle in 1662. It has since been found that every other gas behaves, within certain limits, in a similar way. All these experimental facts are summed up in one general statement, called Boyle's Law, viz.: **When the temperature is constant, the volume of a given mass of gas is inversely proportional to the pressure upon it.**

The law may be conveniently expressed in symbols thus:—Let  $P$  be the pressure, and  $V$  be the volume of a given mass of gas (at temperature  $T^\circ$  A.); if the pressure is altered to  $P'$ , the volume changes to, say,  $V'$ .

Then the law states that  $PV = P'V'$ ,  $T$  being constant. Suppose the volume  $V$  of a gas and its pressure  $P$  are known, and it is required to calculate the new volume  $V'$  resulting from the pressure changing to  $P'$ , which is also known.

From above equation  $V' = V \times \frac{P}{P'}$ .

By inserting the known values of  $V$ ,  $P$ , and  $P'$ , that of  $V'$  is found.

## EXAMPLES VIII (b).

1. If 100 c.c. of air are under a pressure of 760 mm. of mercury, what will be the volume at (a) 780 mm., (b) 740 mm.?

2. When the barometer stands at 75 cm. some air occupies 500 c.c. What additional pressure is needed to compress it to 400 c.c.?

3. If 1 c.c. of mercury weighs 13.6 g., what would be the length (in cm.) of a column of water requisite to balance a column of mercury 76 cm. long?

4. The pressure on some coal gas changes from 28 in. of mercury to 32 in. At the latter pressure the volume is 6 litres. What was its volume before the pressure changed?

5. At a pressure of 14 lb. per sq. in. some air occupies 15 cub. ft. What will be its volume under a pressure of (a) 12 lb. per sq. in., and (b) 16 lb. per sq. in.?

6. If the specific gravity of glycerine be 1.26, find the height of a glycerine barometer when that of a mercurial one is 30 inches?

7. What decrease in volume of 1 litre of air at normal pressure will result from an increase of 20 mm. in the pressure?

8. At what pressure will air have half its normal density?

9. What is the total pressure under which the density of air will be trebled?

10. Some air in an inverted cylinder standing over mercury measures 180 c.c. The level of mercury in the cylinder is 20 cm. above that in the trough. The barometer stands at 750 mm. Find (a) the pressure of the air, (b) the volume it would occupy if mercury was poured into the trough until the level was the same as that in the cylinder.

11. Find the pressure on the air in Question 10 when water is substituted for mercury. (Sp. g. of mercury, 13.6.)

12. Describe the construction and method of using a standard barometer.

13. How may the truth of Boyle's Law be tested in the case of coal gas? Give full details.

**The alteration of the volume of a gas due to the simultaneous alteration of its temperature and pressure.**

By means of the laws of Boyle and Charles we can calculate the volume which a given mass of gas will occupy at any temperature and pressure, provided we know its volume at one temperature and pressure.

Suppose it is required to find the volume of a gas at 30° C. and 780 mm. pressure, knowing that at 15° C. and 770 mm. pressure it occupies 40 c.c.

The calculation may be done in two stages:

- (1) Find the change in volume due to change in temperature alone, the pressure being supposed to remain constant, and then
- (2) Find the alteration in volume due to change of pressure, the temperature being constant.

Thus (1) using the law of Charles—

$$\text{Vol. at } (273 + 15)^{\circ}\text{A. and 770 m.m.} = 40 \text{ c.c.}$$

$$\text{,, ,, } 1^{\circ}\text{A. ,, ,,} = \frac{40}{(273 + 15)} \text{ c.c.}$$

$$\text{,, } (273 + 30)^{\circ}\text{A. ,, ,,} = \frac{40 \times (273 + 30)}{(273 + 15)} \text{ c.c.}$$

(2) Using the law of Boyle—

$$\text{Vol. at } (273 + 30)^{\circ}\text{A. and 1 mm.} = \frac{40 \times (273 + 30) \times 770}{(273 + 15)} \text{ c.c.}$$

$$\text{,, ,, ,, } 780 \text{ mm.} = \frac{40 \times (273 + 30) \times 770}{(273 + 15) \times 780} \text{ c.c.}$$

The symbolical expressions for the laws of Charles and Boyle may be combined for the purposes of such calculations.

Using the same symbols as before—

Boyle's Law is  $V \propto \frac{1}{P}$  when  $T$  is constant.

Charles's Law is  $V \propto T$  ,,  $P$  ,, ,,

Then by a theorem in algebra,  $V \propto \frac{T}{P}$  when both  $T$  and  $P$  vary.



Hence 
$$V = k \frac{T}{P} \quad (\text{i}),$$

where  $k$  is a constant depending only on the mass of the gas.

Suppose  $P$  changes to  $P'$ ,  $T$  to  $T'$ , then  $V$  will change, say, to  $V'$ .

Then 
$$V' = k \frac{T'}{P'} \quad (\text{ii}).$$

Eliminating  $k$  we have 
$$\frac{VP}{T} = \frac{V'P'}{T'}.$$

Knowing any five of these quantities we can find the sixth.

In comparing the volumes of gases it is necessary to know the conditions of temperature and pressure under which they were measured. If they were measured under the same conditions no correction is required. If, on the other hand, the temperature and pressure were not the same, the volumes must be corrected, i. e. reduced to the volumes they would occupy if they were at the same temperature and pressure.

It is usual for purposes of comparison to reduce volumes to 'normal' or 'standard' conditions, i. e.  $0^{\circ}\text{C}$ . and 760 mm., often written as N.T.P. or S.T.P.

For example, it is required to find if the volume of air driven off on boiling 2 litres of tap water is the same as that obtained from the same volume of another specimen.

In the first case, 30 c.c. of air measured at 780 mm. and  $15^{\circ}\text{C}$ . are obtained.

In the second case, 29 c.c. of air are collected, measured at 760 mm. and  $10^{\circ}\text{C}$ .

Both these volumes must be reduced to the same temperature and pressure; for example, to S.T.P.

Using the laws of Boyle and Charles—

(1) 30 c.c. at 780 mm. and  $15^{\circ}\text{C}$ . become

$$\frac{30 \times 780 \times 273}{760 \times 288} \text{ at S.T.P.} = 29.18 \text{ c.c.}$$

(2) 29 c.c. at 760 mm. and  $10^{\circ}\text{C}$ . become

$$\frac{29 \times 760 \times 273}{760 \times 283} \text{ at S.T.P.} = 28.07 \text{ c.c.}$$

## EXAMPLES VIII (c).

1. At  $15^{\circ}\text{C}$ . and 740 mm. pressure a gas occupies 85 c.c. What volume will it have at S.T.P. (i.e.  $0^{\circ}\text{C}$ . and 760 mm. pressure)?
2. Find the volume at  $25^{\circ}\text{C}$ . and 780 mm. pressure of a mass of gas occupying 15 litres at S.T.P.
3. What volume will 16 litres of air at  $-10^{\circ}\text{C}$ . and 750 mm. pressure occupy at  $+10^{\circ}\text{C}$ . and 770 mm. pressure?
4. The temperature and pressure of a certain volume of air (measured at  $20^{\circ}\text{C}$ . and 700 mm.) change to  $10^{\circ}\text{C}$ . and 800 mm. when it has a volume of 65 cub. in. What was the original volume?
5. A certain mass of gas occupies 18 c.c. at  $25^{\circ}\text{C}$ . At  $50^{\circ}\text{C}$ . and when the barometer stands at 29 in. its volume is 21 c.c. What was the original pressure in inches of mercury?
6. What alteration in pressure would be necessary to change the volume of 3.5 cub. ft. of air at  $7^{\circ}\text{C}$ . and at a pressure of 14 lb. per sq. in. to 3 cub. ft. at  $14^{\circ}\text{C}$ .?
7. Find whether (a) 18 c.c. of air at 740 mm. and  $30^{\circ}\text{C}$ ., or (b) 18 c.c. of air at 750 mm. and  $10^{\circ}\text{C}$ ., would occupy the greater volume at S.T.P.
8. Calculate the weight of 1 litre of air at  $15^{\circ}\text{C}$ . and 750 mm., taking the weight at S.T.P. as 1.293187 g.
9. What is the density of air at S.T.P. relative to that of water at  $4^{\circ}\text{C}$ .? Taking the relative density of mercury as 13.6, calculate the height of the atmosphere on the assumption that its density is uniform.
10. A litre of air at S.T.P. is heated to  $125^{\circ}\text{C}$ . and its density is found to have been halved; what alteration in pressure has it undergone?

## CHAPTER IX

### EVAPORATION, VAPOUR PRESSURE, AND BOILING OF LIQUIDS

#### **Preliminary Questions on Evaporation and Boiling.**

1. When a saucerful of cold water is placed in the open air the water gradually evaporates. Explain what becomes of it, and state whether it vanishes slower or quicker (*a*) on a still clear day, (*b*) in a dry wind, (*c*) in a fog, (*d*) in bright sunshine, than on a dull cold day.

2. Water disappears when boiled. Contrast boiling with evaporation, pointing out (*a*) the differences, (*b*) the similarities.

3. Mention any liquids you know which evaporate (*a*) quicker, (*b*) slower than water, all being under the same conditions.

4. Mention some liquids which boil at (*a*) lower, (*b*) higher temperatures than water. Do you think these lists will be the same as those in Question 3?

5. Can solids evaporate? If your answer is in the affirmative, give examples.

6. Do you think water will evaporate (*a*) at all, (*b*) as much when a dish of it is placed under a glass shade as when freely exposed to the air? Give an account of any observations you have made.

7. Will equal quantities of cold and warm water evaporate at the same rate? How could you test the truth of your answer?

8. How is it that damp clothes dry quicker in front of a fire than in colder places?

9. If you wanted to evaporate a liquid quickly would you put it in a deep, narrow beaker, or in a wide, shallow dish? Give reasons.

10. Sum up the conditions which you think are favourable to rapid evaporation.

**Exp. 1. To find the effect of placing air and liquids in barometers.**

*Required:—4 barometer tubes with stand and trough, mercury, 4 bent pipettes, freshly boiled water, benzene.*

#### DIRECTIONS.

*A.* Make four barometers, *A*, *B*, *C*, and *D*, using perfectly clean dry mercury, and place them side by side.

By means of bent pipettes introduce a little air into *B*; cold, recently boiled water into *C*; benzene into *D*.

(In the case of liquids enough must be put to form a distinct layer above the mercury.)

**Note** the effects in each case, and measure the height of the mercury in each tube above that in the trough.

Introduce a little more of the three substances into their respective tubes.

**Note** the tubes in which a further depression (*a*) does, (*b*) does not, occur.

Now put a little benzene into *C* in addition to the water, and **notice** the effect.

Next, warm the upper part of each tube, either by holding it with your hand, or by moving a small flame along it.

**Note** the tubes in which there is a depression of mercury.

#### LABORATORY NOTES.

Diagram and complete observations for each tube in a schedule, thus:—

Tube	<i>A</i>	<i>B</i>	<i>C</i>	<i>D</i>
Space over mercury contains	Nothing.	Air.	Water.	Benzene.
Effect of further additions.				
Effect of warming.				

- Questions*:—(i) Is the depression in the tubes *C* and *D* due to the liquid or its vapour? Give reasons.
- (ii) How do you account for the difference of effects in *B* and *C* after further additions of air and water respectively?
- (iii) How do you explain the results of heating the tubes?
- (iv) Explain clearly how you would find the pressure of the air in *B*.

**Vapour Pressure.** The last experiment will have shown (a) that when different liquids are allowed to evaporate *in a closed space*, their vapours exert different pressures; (b) that, provided a certain minimum quantity of a liquid is present, an additional quantity does not increase the formation of vapour; (c) that the vapour pressure increases with increase of temperature; (d) that when a space contains the maximum amount of the vapour from one liquid, it does not prevent the formation of vapour from a second liquid when mixed with the first.

These facts bear a resemblance to those observed in the experiments of Chapter VI on the solubility of solids in liquids, and some of the terms used to describe the latter are also used to describe the former. The closed space corresponds to a given quantity of the solvent; at a given temperature this space can only contain a certain quantity of a vapour, just as a solvent will only dissolve a fixed quantity of a solid at a given temperature. When the solvent has dissolved the maximum quantity of the solid it is said to be 'saturated' with the dissolved solid; so also, when a space contains the maximum amount of a given vapour, it is said to be saturated with the vapour, and the vapour is said to exert the maximum vapour pressure of which it is capable at that temperature. The addition of more of the solid to a saturated solution does not cause any more solid to dissolve, neither does the addition of liquid to a saturated vapour cause any more liquid to evaporate, but an increase of temperature generally

increases the solubility of a solid, the amount of the increase depending on the nature of the solid. Just as an increase of temperature increases the saturation pressure of the vapour, so the exact amount of increase depends on the liquid used. Further, if a solid is put into a saturated solution of a second solid, the first will dissolve just as if the other were not present; so a space saturated with one vapour will allow another liquid to evaporate into it to the same extent as into a vacuum. (In both cases it is assumed that the two solids and the two liquids exert no 'chemical' action on one another.)

Exp. 1 shows how the saturation pressure of a vapour can be found at the air temperature. By surrounding the top of the tube with a water-jacket, and by placing water at different temperatures in it, the saturation pressure at any other temperature up to 100° C. can be found.

In measuring the total pressure due to two vapours a different form of apparatus is required, because the addition of the second vapour depresses the mercury and enlarges the volume occupied by the first vapour. From Boyle's Law it follows that if the volume occupied by a gas or vapour increases, its pressure is diminished. Hence, before measuring the total pressure, the volume must be made the same as before. When this is done it is found that **a mixture of vapours, e. g. water and benzene, exerts a pressure equal to the sum of the pressures of the separate vapours.** This fact was discovered by John Dalton, and is known as the *law of partial pressures*. It only applies to vapours of liquids which have no solvent action on one another. If a mixture of alcohol and water is used, the total vapour pressure is found to be less than the sum of the separate vapour pressures. The same is true of other liquids which can mix with (i. e. dissolve in) one another.

The word 'tension' is often used for 'pressure' in this connexion, e. g. 'the "*tension*" of aqueous vapour at 15° C. is 12.7 mm. of mercury.'

**Evaporation.** These facts lead to a better understanding of the process of evaporation. It has been shown that a liquid will only evaporate to a limited extent in a *closed space* at a given temperature. In an open space, however, the evaporation will go on until there is no liquid left, provided that the space never becomes saturated with the vapour. It follows that water at the air temperature will not evaporate at all on a wet day, because the atmosphere is saturated with water vapour at that temperature. If, however, the water (and consequently the air in its vicinity) is heated, evaporation will go on until the air is saturated at the higher temperature. When air saturated with water vapour is suddenly cooled, part of the vapour condenses to a liquid, just as a hot saturated solution precipitates some of the solid on cooling. Warm currents of air, saturated with aqueous vapour, when cooled by contact with colder air or land, deposit their vapour in minute drops, causing fogs or clouds.

**Ebullition.** On heating a liquid in air its vapour pressure gradually increases, and evaporation proceeds at an increasing rate, until a temperature called the boiling-point is reached. Provided that the vessel is not closed, it is impossible to raise the temperature of the liquid above this point.

It is plain that the vapour is formed, not only at the surface, as in evaporation at lower temperatures, but throughout the whole mass of liquid, especially at the part nearest the source of heat. Hence, boiling or ebullition is a special case of evaporation, taking place throughout the liquid, and not merely at the surface.

The question arises as to what the pressure of the vapour is at the boiling-point, and why the temperature remains constant until the liquid is entirely converted into vapour

**Exp. 2. To show the influence of temperature on the pressure of water vapour.**

*Required:—Apparatus as in Fig. 36.*

#### DIRECTIONS.

Through the open end X (Fig. 36) of the U-tube (bore = 5 mm.) pour in some dry mercury.

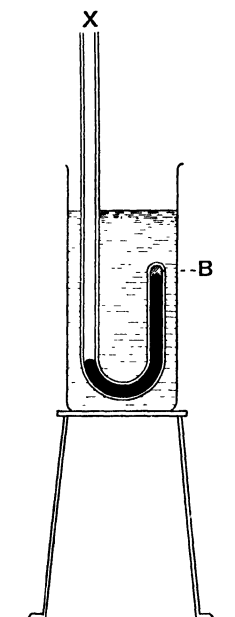

FIG. 36.

Incline it so as to replace the air in the closed limb entirely with mercury.

Fill up the open limb also to within 5 mm. of X, and then fill the remaining space with recently distilled water.

Close X with the thumb, and invert the tube until the water passes to the bend; then carefully incline it until the water reaches B.

Pour out about three-quarters of the mercury in the open limb, being careful to avoid letting air into the closed limb.

Clamp the tube in a beaker of water, as shown in Fig. 36.

Heat the water until it boils, and observe the level of mercury in both limbs.

#### LABORATORY NOTES.

Draw a diagram, and record all your observations.

*Questions:—*(i) What is the pressure of the aqueous vapour in B when the water in the beaker is boiling?

(ii) Try to account for the fact that at atmospheric pressure a liquid cannot be heated beyond its boiling-point.



- (iii) What becomes of all the heat supplied to a boiling liquid from the lamp?
- (iv) How do you explain the fact that pure water boils on some days at  $99.5^{\circ}\text{C}$ . and at others at  $100.5^{\circ}\text{C}$ .?
- (v) Would you expect any difference to be found in water boiling (a) at the top, (b) at the foot of a mountain on the same day? Give reasons.
- (vi) What was the object of using recently distilled water? Would unboiled tap water have given similar results? State reasons.

### PROBLEM (IX. 2).

Repeat the experiment using benzene instead of water in the U-tube<sup>1</sup>, and constantly stir the water in the beaker during the experiment. Note the temperature when the level of mercury in both limbs is the same.

Then find the boiling-point of benzene, using a water-bath to heat the liquid. (The water should be hot before putting the vessel containing the benzene in the bath, and the flame should be turned out.)

Compare the two temperatures.

<sup>1</sup> A fresh dry U-tube must be used.

## EXAMPLES IX (a).

1. The volume of some dry air standing in a graduated tube over mercury reads 50 c.c. The height of the mercury in the tube above that in the trough is 15 cm. ; the barometer reading is 755 mm. What is the pressure of the air? What volume would it occupy at 760 mm. pressure?

2. 200 c.c. of air stand in an inverted cylinder over water at  $10^{\circ}\text{C}$ . The water level is the same inside and outside the cylinder. What is the pressure of this air? [Barometer reading is 753 mm. ; tension of aqueous vapour at  $10^{\circ}\text{C}$ . is 9.1 mm.]

3. 50 c.c. of air saturated with moisture at  $15^{\circ}\text{C}$ . stands over mercury as in Question 1. Find the pressure of the dry air at  $15^{\circ}\text{C}$ . and its volume at 760 mm. of mercury pressure. (Pressure of water vapour at  $15^{\circ}\text{C}$ . = 12.7 mm. of mercury.)

4. How could you find out whether some air confined in a tube over mercury was dry or not?

5. In what way would you find whether water at  $0^{\circ}\text{C}$ . exerts any vapour pressure? Give details of your method.

6. Mercury boils at  $358^{\circ}\text{C}$ . Would you expect it to exert a vapour pressure at  $15^{\circ}\text{C}$ .? Do you think that the space above the mercury in a barometer tube is a perfect vacuum? Give reasons?

7. 100 c.c. of dry air are measured at  $20^{\circ}\text{C}$ . and at 765 mm. pressure. If the air be now saturated with moisture what volume will the damp air occupy, its pressure remaining 765 mm.? [The pressure of aqueous vapour at  $20^{\circ}\text{C}$ . is 17.4 mm.]

8. What weight of water vapour is contained in 1 cubic metre of air saturated at  $20^{\circ}\text{C}$ . and having a pressure of 753 mm.? [Pressure of aqueous vapour at  $20^{\circ}\text{C}$ . is 17.4 mm., and weight of 1 litre of aqueous vapour at  $0^{\circ}\text{C}$ . and 760 mm. is .8064 g.]

## CHAPTER X

### THE MEASUREMENT OF HEAT. SPECIFIC HEAT

**Distinction between Heat and Temperature.** Exp. 4 (p. 52) showed that while ice is melting its temperature, as indicated by a thermometer, remains unchanged, although it is receiving large quantities of heat from the burner.

This *fact* shows the necessity for two distinct expressions to indicate the thermal condition of a melting solid. One is required to describe its effect on a thermometer or on the hand—this is called its *temperature* or the intensity of its heat. The other is required to indicate that the solid may be receiving heat without altering its temperature, i. e. to indicate that the liquid produced has more heat in it than the solid, although the temperature is unaltered. The liquid is said to contain a greater *quantity of heat* than the solid.

When heat is added to the *liquid*, then its temperature does rise as far as the boiling-point. Hence, when heat is imparted to a body it may either (*a*) alter its physical state without altering its temperature, or (*b*) alter its temperature without altering its physical state. Although the latter shows that there is a close connexion between the quantity of heat received by a body and the increase of its temperature, the former shows that the two things are really distinct.

The quantity of heat contained in a thimbleful of boiling water or a red-hot poker is much less than that in a large bucketful of lukewarm water, for neither of the former will melt so much ice as the latter.

The quantities of heat given out by bodies in cooling can be compared by finding the weights of ice they will melt, or by a simpler method, as in the following experiments.

**Exp. 1. To observe the temperature of a mixture of known quantities of warm and cold water.**

*Required*:—*Measuring jar*; *2 tin cans or beakers (500 c.c.)*; *thermometer*.

**DIRECTIONS.** *A. Equal quantities.*

By means of a measuring jar transfer 200 c.c. of ordinary water to each of two tin cans (or beakers).

Heat one gently over a tripod until it is at about 30° C. Turn out the lamp and place the vessel by the other on the bench.

Stir the water and take the temperature in each case, estimating to  $\frac{1}{10}$  of a degree.

**Record** these temperatures.

As quickly as possible, pour the cold water into the hot water and stir.

**Note** the temperature of the mixture.

*Precautions.* (a) The warm water must not remain on the tripod during the mixing.

(b) The temperatures must be taken *immediately* before mixing.

*B.* Repeat the experiment, but pour the warm water into the cold.

The temperatures before mixing must be the same as in *A*.

*C. Unequal quantities.*

Repeat *A*, using 300 c.c. of water at 30° and 100 c.c. at the air-temperature.

*D.* Repeat *C*, but pour the warm water into the cold water.

**LABORATORY NOTES.** Record your results thus:—

	<i>A</i>	<i>B</i>	<i>C</i>	<i>D</i>
<i>Cold water</i> { Weight . . . Temperature	( <i>x</i> °)		( <i>m</i> grams) ( <i>t</i> °)	
<i>Warm water</i> { Temperature Weight . . .	( <i>y</i> °)		( <i>t</i> '°) ( <i>m'</i> grams)	
<i>Mixture</i> —temperature . . .	( <i>s</i> °)		( <i>T</i> °)	

- Questions.* (i) Compare the mean temperature of the warm and cold water in *A* and *B* with the observed temperature of the mixture, i. e. compare  $\frac{x+y}{2}$  with  $s$ .
- (ii) If the temperature of the mixture in *A* is not the same as in *B*, account for the difference.
- (iii) Compare the mean temperature of the *mixtures* in *A* and *B* with the mean temperature of the warm and cold water.
- (iv) In *C* and *D* calculate the quantity of heat received by the *cold* water in being warmed to the temperature of the mixture, i. e. find the value of  $m(T-t)$ .
- (v) In *C* and *D* calculate the quantity of heat lost by the *warm* water in cooling to the temperature of the mixture, i. e. find  $m'(t'-T)$ .
- (vi) Compare the numerical values of  $m(T-t)$  and  $m'(t'-T)$ .
- (vii) Compare the quantities of heat required to raise (a) 100 g., (b) 200 g. of water from 15° C. to 30° C.
- (viii) Compare the quantities of heat required to raise 100 g. of water at 15° C. (a) to 30° C., (b) to 45° C.
- (ix) Give reasons for the precautions.

#### Unit Quantity of Heat.

Exp. 1 shows that when equal weights of hot and cold water are mixed, the temperature of the mixture is approximately equal to the mean of the temperatures before mixing. The results obtained may not appear to support this statement *exactly*, but this is due to certain experimental errors which were not corrected. Thus, it was assumed that all the heat lost by the hot water went to warm the cold water, but part of it went also to warm the vessel. Other small errors arise from the facts that the whole of the water cannot be poured out of a vessel; that the warm water is cooled when it is poured through the air; that the mixture is cooling while being stirred. When these errors are eliminated the statement is found to be very approximately true.

The following conclusions can be drawn, viz.:—When

a given mass of water cools through a certain range of temperature it loses as much heat as is required to raise it through the same range of temperature, for 200 g. of water in cooling from  $30^{\circ}\text{C.}$  to  $22.5^{\circ}\text{C.}$  (i.e. through  $7.5^{\circ}$ ) raise the temperature of 200 g. at  $15^{\circ}\text{C.}$  to  $22.5^{\circ}\text{C.}$  (a range of  $7.5^{\circ}$ ). Hence the amount of heat required to raise the temperature through a range of  $1^{\circ}$  is the same at any part of the thermometer scale. Again, 2 g. of water require twice as much heat to raise them through the same range as 1 g. does. Hence the amount of heat required to raise the temperature of a body through  $1^{\circ}$  is directly proportional to the mass of the body. Similarly, twice as much heat is required to raise 1 g. of water through  $2^{\circ}\text{C.}$  as is required to raise it through  $1^{\circ}\text{C.}$  Therefore the quantity of heat received by a body is directly proportional to the range of temperature through which it is raised.

It will be plain that the temperature of a body does not measure the quantity of heat which has been imparted to it, but is only one factor in this measurement; the mass has also to be taken into account.

These considerations show a means of measuring a quantity of heat if some unit is agreed upon. Thus if we agree to say that 1 unit of heat is received when 1 g. of water is raised through  $1^{\circ}\text{C.}$ , then  $m$  g. receive  $m$  units for a range of  $1^{\circ}\text{C.}$ , and  $m(t' - t)$  units when the range is from  $t^{\circ}\text{C.}$  to  $t'^{\circ}\text{C.}$  This is the unit which has been agreed to in the Metric System and is called a *calorie*. On other systems other units can be taken, though this is now unusual.

In general terms the **unit quantity of heat** may be defined as *that quantity of heat required to raise unit mass of the standard substance (water) through unit range of temperature.* The metric unit is commonly used, and is defined thus:—A **calorie** is the quantity of heat received (or lost) by 1 gram of water when its temperature rises (or falls) through  $1^{\circ}$  centigrade.

**Exp. 2. To observe the temperature of a mixture of known weights of cold water and hot metals.**

*Required:—As for Exp. 1; disks of lead, iron, and copper, each weighing 400 g., having a hole drilled through the centre through which a piece of string passes; balance.*

### DIRECTIONS.

A. Weigh one of the metal disks and place it in a can half-full of water. Heat the water and let it boil for at least five minutes.

Meanwhile measure out 200 c.c. of water into another can, placed on the bench away from the burner.

Stir with a thermometer and **note** its temperature.

**Note** the temperature of the boiling water (and therefore of the metal).

Quickly transfer the metal to the cold water.

Stir with a thermometer and **note** the highest temperature to which the water rises.

B. Repeat A with at least two other metal disks.

### LABORATORY NOTES.

Arrange your results thus:—

Hot ——. (Insert name of metal.)		Cold Water.	
Mass	= — g. (M)	Mass	= — g. (m)
Temperature	= — °C. ( $t^c$ )	Temperature	= — °C. ( $t$ )
Common temperature after mixing = — °C. ( $T^c$ )			

Calculate the heat received by the water, viz.  $m(T-t)$  calories, from each metal.

*Questions.* (i) Do equal weights of different metals impart the same amount of heat to the water?

(ii) What are the chief errors in the experiment? Show whether they make the temperature of the mixture higher or lower than it would be if they had been avoided.

[Over

- (iii) Divide the heat given to the water by the mass of the metal and by the range of temperature ( $t' - T$ ) through which it has fallen, and thus find the quantity of heat given out by 1 g. of metal in falling through  $1^\circ \text{C}$ .

### PROBLEM (X. 2).

Find how many calories are required to raise the temperature of the tin can through  $1^\circ \text{C}$ .

Weigh one dry empty tin can. Nearly fill the other with water and boil it. Take the temperatures of the boiling water and of the air inside the empty can. Pour the boiling water into the latter, stir and take the temperature. Then find the weight of water used.

Repeat twice more, estimating temperatures to  $\frac{1}{10}$  of a degree. Calculate the heat given out by the water and divide it by the rise in temperature of the can. Take the mean of three fairly concordant results.

### Specific Heat.

Exp. 2 will have clearly shown that equal weights of different metals do *not* give out equal quantities of heat when they fall through the same range of temperature. Using the same symbols as before the heat received by the water is  $m(T - t)$  calories. This has come from  $M$  g. of metal in falling from  $t^\circ$  to  $T^\circ$ . Hence 1 g. of metal gave out  $\frac{m(T - t)}{M}$  calories in falling from  $t^\circ$  to  $T^\circ$ ; and  $\frac{m(T - t)}{M(t' - T)}$  calories in falling through  $1^\circ \text{C}$ .

1 g. of each metal gave out a *different* amount of heat in falling  $1^\circ \text{C}$ ., and in all cases it was much less than 1 calorie. The same is found true of other substances; they all differ in this respect, just as they differ in density and



other properties. The fraction of a calorie required to raise 1 g. of a substance through 1° C. is called the *specific heat* of the substance. It is defined in general terms as follows:—The **specific heat** of a substance is the number of units of heat required to raise unit mass of the substance through unit range of temperature.

It may also be expressed as a ratio thus:—

$$\text{Sp. ht. of a body} = \frac{\text{Quantity of heat required to raise a known mass through a known range of temperature.}}{\text{Quantity of heat required to raise an equal mass of water through the same range of temperature.}}$$

The values of the specific heats of some common substances are given below:—

Name.	Specific Heat.	Name.	Specific Heat.
Copper . . .	·095	Water . . .	1
Iron . . . .	·114	Alcohol . .	·062
Lead . . . .	·031	Glycerine . .	·555
Tin . . . . .	·055	Turpentine .	·426
Ice . . . . .	·489	Mercury . .	·033
Brass . . . .	·094	Air . . . . .	·237
Glass . . . .	·198	Steam . . . .	·481

The quantity of heat required to raise a given mass of a body through 1° C. is called the *heat-capacity* of that mass. Thus in the problem (p. 158) the object was to find the heat-capacity of the tin can, irrespective of its mass.

Specific heat may also be defined as the *capacity for heat of unit mass* of a substance.

## EXAMPLES X.

1. 50 g. of water at  $100^{\circ}\text{C}$ . are mixed with (a) 60 g. of water at  $20^{\circ}\text{C}$ ., (b) 80 g. at  $40^{\circ}\text{C}$ ., (c) 200 g. at  $0^{\circ}\text{C}$ . Calculate the temperature of each mixture.

2. What is a calorie? How many are required to warm (a) 20 g. of water from  $25^{\circ}\text{C}$ . to  $65^{\circ}\text{C}$ ., (b) 50 g. of water from  $0^{\circ}\text{C}$ . to  $100^{\circ}\text{C}$ . ?

3. How many calories are needed to warm 20 g. of water from  $65^{\circ}\text{F}$ . to  $165^{\circ}\text{F}$ . ?

4. If the unit of heat is defined as the quantity required to raise 1 lb. of water through  $1^{\circ}\text{F}$ ., how many of these units are required to heat 25 lb. of water (a) from  $50^{\circ}\text{F}$ . to  $100^{\circ}\text{F}$ ., (b) from  $20^{\circ}\text{C}$ . to  $40^{\circ}\text{C}$ . ?

5. Explain the statement 'the specific heat of copper is .095.' How can the specific heat of copper be found experimentally?

6. On what assumption does the method of determining specific heats by mixing a hot and a cold substance depend? Name the principal experimental errors liable to be made and suggest methods for correcting them.

7. How many calories are requisite to heat (a) 80 g. of copper, (b) 100 g. of brass, (c) 150 g. of mercury from  $20^{\circ}\text{C}$ . to  $70^{\circ}\text{C}$ . ? [Refer to table of specific heats on p. 159.]

8. 200 g. of a metal at  $100^{\circ}\text{C}$ . are mixed with 80 g. of water at  $20^{\circ}\text{C}$ . The temperature of the mixture is  $29.5^{\circ}\text{C}$ . Calculate the specific heat of the metal.

9. What will be the temperature of a mixture of 200 g. of lead (sp. ht. .031) at  $150^{\circ}\text{C}$ . with 100 g. of water at  $15^{\circ}\text{C}$ . ?

10. 200 g. of water at  $99.5^{\circ}\text{C}$ . are poured into an empty vessel at  $15.5^{\circ}\text{C}$ . After stirring the temperature is  $97^{\circ}\text{C}$ . How many calories are required to raise the temperature of the vessel through  $1^{\circ}\text{C}$ . ?

## CHAPTER XI

### IDENTIFICATION OF SUBSTANCES BY THEIR PHYSICAL PROPERTIES

THE experiments of preceding chapters have shown how some of the common physical properties of substances can be ascertained. In order to identify a given substance it is necessary to investigate as many of these properties as possible, and to compare them with those of known substances. In this investigation mere inspection informs us to which of the three great groups—solids, liquids, and gases—it belongs. The more obvious properties, such as colour, crystalline form, smell, taste, may possibly be useful; but they will not take us far, since many substances have the same colour, several have the same crystalline form, and, if the substance is a powder, this distinction fails; many, again, have no smell or taste. It is therefore necessary to make experiments with a view to ascertaining those properties which though less obvious are more distinctive.

**Solids.** In the case of solids the relative density, melting-point, and solubility in liquids will usually give the means for identification; the density can always be found with accuracy, and as scarcely any two substances have the same density, this is perhaps the most valuable method. The melting-point is useful where the quantity of the body is small, and as it can be quickly determined, this means is very often used; the solubility takes longer to determine, and as it varies so much with slight changes of temperature, is not so useful as the others.

In addition to these properties it is often helpful to find whether the substance is hard or soft, brittle or malleable, i. e. capable of being beaten out into a thin sheet, like lead,

tin, copper, &c. Though it is difficult to lay down rules for procedure to cover all possible cases, the general idea is to make as complete an investigation as possible; in this way the chances of mistaking one substance for another, owing to their possession of several common properties, are considerably reduced.

Suppose it is required to find out whether two white powders are different substances or merely two specimens of the same substance. The quickest way is to determine their *melting-points*, having first found a suitable liquid in which to heat them.

If they do not melt at a sufficiently low temperature, a determination of their *densities* should be made. To do this, first find some liquid in which they are insoluble; weigh each in air, and then find their volumes by displacement of the liquid.

In testing the *solubility* it might happen that a difference between the substances would be revealed; in this case the problem is solved, because a single distinction is enough to show that they are different. It must be remembered, however, that a single resemblance is not enough to prove that they are identical.

It is usual to speak of the peculiarities which substances possess with regard to density, melting-point, &c., as 'characteristic' or 'specific' properties; the terms *characteristic* and *specific* meaning the same as 'distinguishing,' 'peculiar,' or 'special.' Thus sulphur has the characteristic property of melting at 114° C., and has a specific gravity of 2.07. Where a numerical value can be given to the properties considered, such values are referred to as the *physical constants* of the substance. For example, the physical constants of tin are M.P. 235° C.; sp. g. 7.3; latent heat of fusion 14.25, &c.

**Liquids.** The most characteristic properties of a liquid are its *boiling-point* and *specific gravity*. Very few liquids have the same B.P., and in those cases where they are

nearly the same there is generally some obvious property, such as smell, by which they can be distinguished. The determination of the boiling-point is a valuable means for finding whether a given liquid is a mixture or a single substance. A mixture has very rarely a constant boiling-point, whereas a pure liquid always has.

The specific gravity is most accurately and quickly ascertained by means of a specific gravity bottle.

**Gases.** Using air as a typical gas it has been shown to possess mass, but to have a very much lower density than water; to expand considerably on heating; to be slightly soluble in water; to exert pressure; and to be easily compressible. Since the rate of expansion and compression are the same for all gases, these two properties are of no help in identification. Gases differ most in density, but they are usually distinguished by other properties, which will be dealt with in Part II of this Book.

**The three physical states of matter.** Solids, liquids, and gases all have certain properties in common, such as the possession of mass, occupation of space, &c. These fundamental properties are those by which material things are distinguished from immaterial things, like light, heat, &c. The term 'matter' is very difficult to define, but it will suffice for our purposes to consider it as anything having mass and occupying space. Solids, liquids, and gases are, therefore, three forms of matter readily distinguished from one another by certain properties, such as rigidity in solids, lack of rigidity, i. e. fluidity, in both liquids and gases; very low specific gravity, high coefficient of expansion, &c., distinguish gases from liquids. Now it is well known that the same substance can exist in the solid state at certain temperatures, and in the liquid or gaseous states at others. For instance, ice, water, and steam are the solid, liquid, and gaseous forms of the same substance. Hence it is usual to refer to these different forms in which matter exists as the three physical states of matter.

## PROBLEMS IN IDENTIFICATION

1. Find out whether the liquid *A* is pure alcohol by determining its boiling-point.

2. The liquid *B* is suspected to contain, besides water, another substance of nearly the same boiling-point. Find whether this is so or not by determining its density at the temperature of the laboratory, and comparing the result with that for water at the same temperature.

3. It is uncertain whether *C* is Epsom salt or not. Devise a means of settling the question.

4. *D* is a specimen of salt, but may contain a trace of fine sand. Find out whether it does or not.

5. The lump of metal *E* is either pure copper or an alloy containing a lighter metal. Which is it?

6. Ascertain whether *F* is pure washing soda by finding its percentage of water of crystallization.

7. The yellow solid *G* is either brass or iron pyrites; find which it is by determining its density.

8. Find out whether *H* is iodine or graphite (blacklead).

**Data Required.**—B. P. of alcohol, 79° C.; sp. g. of copper, 8.93. Washing soda contains 62.9 per cent. of water; sp. g. of brass, 8; sp. g. of iron pyrites, 5.

## ADDITIONAL PRACTICAL PROBLEMS

1. Test the accuracy of a burette by weighing 10 c.c. of water taken from it. Take 10 c.c. from various parts of the burette, and compare the results with the mass of 10 c.c. of water at the temperature of room. (Refer to tables for this.)

2. Find the volume of a metal sphere. Calculate the volume of a cylinder of equal height, and having the area of its circular end equal to that of a central section of the sphere. Compare the two volumes and deduce an expression for the volume of a sphere in terms of  $\pi$  and  $r$ ,  $2r$  being the diameter of the sphere.

3. Work Problem 2 for a right cone instead of a sphere. Obtain a formula for the volume of a cone in terms of  $\pi$ ,  $r$  (radius of circular end) and  $h$  the height.

4. Weigh a piece of zinc foil of known area. Find its relative density. Hence calculate its thickness. Measure the thickness directly by a screw gauge and compare the two results.

5. Find the length, thickness, and mass of the given piece of wire; hence calculate its density. Weigh it in water and find its relative density by the method of Archimedes. Compare the two results.

6. Determine the mass of 1 c.c. of a saturated aqueous solution of blue vitriol. Weigh the given crystal of blue vitriol in air and then in the saturated solution. Hence find the density of the crystal relative to that of water.

7. Find the mean area of cross-section of the given capillary tube about 10 cm. long. Fill the tube with mercury and empty into a weighed dish; weigh again and find the volume of the mercury, given that its sp. g. is 13.6. Measure the length of thread at different parts of the tube and take the mean.

8. Ascertain the relative density of sand, by weighing some in a sp. g. bottle of known weight. Fill up with water, and weigh again. Hence find the volume of sand and then its relative density.

9. Find the melting-point of fusible metal, iodoform, or of picric acid, first finding a suitable liquid in which to heat it. (For temperatures above  $100^{\circ}\text{C}$ . glycerine is useful.)

10. Ascertain the boiling-point of acetic acid (vinegar), and find whether the sample is pure.

11. Obtain as pure a sample of benzene as possible from '50 per cent. commercial benzene.' The pure liquid boils at  $79^{\circ}\text{C}$ .

12. Find the percentage weight of nitre in gunpowder. Use about 2 grams. Heat in water. Filter, wash with hot water. Evaporate the filtrate, and weigh the solid. Dry the residue at  $100^{\circ}\text{C}$ . Weigh this and check the first result.

13. Determine the weight of dissolved solids in 50 c.c. or more of tap-water. Hence calculate the weight per litre.

14. Determine the solubility of potassium chlorate or potassium chloride in water, at intervals of  $10^{\circ}\text{C}$ ., starting at the air temperature. Plot the curve.

15. Weigh out an exact quantity of salt (about 7 grams) and dissolve it in 50 c.c. of water. Find the volume of the solution and calculate the volume of water that should be added to it, so that 100 c.c. of the new solution may contain 5 g. of salt. Add this quantity of water and, after shaking, evaporate 20 c.c. to dryness. From the weight of salt obtained find whether your calculation was correct.

16. Find whether the sand supplied is free from (a) volatile matter, (b) soluble matter.

17. From powders of potassium ferro-cyanide, chrome alum, potassium chlorate, lead nitrate, sal-ammoniac, obtain well-formed crystals.

18. Weigh out about 20 g. of green vitriol and about 10 g. of sulphate of ammonium. Mix them and dissolve in the minimum quantity of boiling water. Filter and crystallize. Compare the obvious properties of the crystals obtained with those of the original substances.



19. Prepare a pure specimen of salt from the rock salt supplied. Dissolve in pure water, filter if necessary, and crystallize. Dry the crystals, and if they are coloured or deliquescent recrystallize them. Explain what has become of the impurities.

20. The given mixture contains equal weights of potassium chlorate (white) and potassium bichromate (red). Obtain a pure specimen of the former by fractional crystallization.

## REVISION QUESTIONS

### CHAPS. I-X

*N.B.—Diagrams should be given wherever they make the answer more complete.*

1. What precautions have to be taken when measuring a length by means of a scale? Give a diagram to illustrate your answer. What is the name for the error introduced by neglecting this precaution?

2. How would you measure the thickness of one page of a book? Explain *clearly* the reasons for your method.

3. Explain the object of taking the 'mean' of a number of observations rather than a single observation.

4. Give a clear and concise account of the use of the vernier.

5. Make a drawing (from memory) of a screw gauge. Describe (a) its construction, and (b) the method of using it.

6. Answer Question 5 for the sliding calipers.

7. Describe two methods for finding the area of an irregular surface. Compare them on the point of accuracy.

8. Find an expression for the area of a regular octagon in terms of the length of one side ( $l$ ) and half the distance ( $p$ ) between the middle points of two opposite sides.

9. Describe a pipette; explain how and for what purpose it is used. How can the accuracy of its graduation mark be tested?

10. What is a meniscus? Describe two forms.
11. When a pipette half immersed in a liquid is tightly closed with the thumb and lifted up, one or two drops fall out. Explain why this occurs.
12. Answer Question 9 for a burette and measuring jar.
13. Give an account of the structure of a Bunsen burner and of the Bunsen flame.
14. How would you proceed to make a thistle funnel from a piece of glass tube?
15. What are the chief precautions to be taken in fitting up apparatus involving a flask, cork, and glass exit tubes?
16. What is meant by 'latent' heat? By what experiments would you convince a person that (a) heat can be rendered latent, (b) that latent heat can be recovered?
17. In finding the boiling-point of a liquid, what are the necessary precautions with regard to (a) the position of the thermometer; (b) bumping; (c) pressure of the atmosphere?
18. What form of apparatus would you use to find the boiling-point of an inflammable liquid such as ether?
19. What parts of a balance are most liable to damage if badly used or insufficiently protected? What precautions should be taken to avoid such damage?
20. Examine the truth of the popular statement—'Bodies weigh less when hot than when cold.'
21. Define the terms 'density,' 'specific gravity,' 'relative density.' How would you determine the sp. g. of water at  $80^{\circ}\text{C}$ .?
22. Describe a relative density bottle, and explain how it can be used to determine the relative density of powdered salt.
23. Two liquids, *A* and *B*, are to be mixed in the proportion of 2 : 3 by weight. Sp. g. of *A* is  $\cdot 7$ , of *B*  $1\cdot 7$ . What volume of *A* must be taken for 100 c.c. of *B*?
24. State the principle of Archimedes, and explain a method for proving its truth. Point out the possible errors in the method.

25. A solution has a relative density of 1.8. How many c.c. of water must be added to 1 litre of it to reduce its relative density to 1.5 ?

26. Two liquids of relative densities .8 and 1.6 stand in a U-tube. The heights of their free surfaces above the bench are 35 cm. and 25 cm. respectively. What is the height of the surface of separation above the bench ?

27. Explain the meaning of the term 'pressure.' Compare the pressures at a depth of 12 cm. due to a column of (a) water, (b) mercury (sp. g. = 13.6). At what depth would the water-pressure be equal to that of 12 cm. of mercury ?

28. Devise an experiment to show that the pressure at a given point under water is the same in a horizontal direction as it is in a vertical direction.

29. What method do you consider is the most accurate for finding the relative density of a liquid? Carefully point out its superiority to two other methods.

30. Define the terms 'filtration,' 'evaporation,' 'decantation,' 'distillation,' and state the object of these processes.

31. Point out the differences between the fusion and solution of a solid. When a solid is dissolved in water a reduction in temperature is often noticed; explain this.

32. Explain in detail how to determine the solubility of a solid in water at 60° C., giving all particulars necessary for ensuring accuracy.

33. 30 c.c. of a solution weighed 33.315 g. and gave 8.865 g. of solid on evaporation. Calculate (a) the solubility of the solid, (b) the weight of solid in 100 c.c. of the solution.

34. How can the percentage of soluble and insoluble matter in a mixture of solids be found? Give all details necessary for accuracy and for checking the result.

35. Describe the process of fractional distillation and explain its use.

36. What is a crystal? What are the best conditions for obtaining well-formed crystals from a solution?

37. State the meaning of 'amorphous,' 'deliquescent,' 'efflorescent.' Mention substances to which the terms apply.

38. Explain how the process of fractional crystallization is carried out. State its object.

39. Some water contains salt and sand. How could you find the percentage weight of the three substances?

40. Describe some form of desiccator. How may it be used to dry a volatile solid?

41. How could you separate a mixture of graphite and iodine without using a liquid?

42. Describe an accurate barometer and explain how it is used.

43. State the laws expressing the relation between the volume of a gas and its temperature and pressure. Explain clearly how each law may be verified.

44. What is meant by the expression 'tension of aqueous vapour at  $15^{\circ}\text{C}$ . is 12.7 mm.'?

If some moist air fills a tube at a pressure of 760 mm. of mercury and at  $15^{\circ}\text{C}$ ., what is the pressure of the dry air?

45. Explain the difference between evaporation and ebullition. Define the term 'boiling-point' of a liquid; and show how you could verify your definition experimentally.

46. How would you determine the vapour pressure of alcohol at  $50^{\circ}\text{C}$ .?

47. What is meant by the expressions, 'saturated solution' and 'saturated vapour'?

48. What are the chief differences (a) between solids and liquids, (b) between liquids and gases?

49. A given powder may be a single substance or a mixture of two. How would you proceed to find out which it was?

# APPENDIX

## TYPES OF VERNIERS

### A. Simple forward-reading vernier.

This type is described on p. 15. See Figs. 1 A and 1 B.

The graduation numbers on V run in the *same* direction as those on S; hence it is termed a *forward-reading* vernier.

If  $v$  is the length of 1 vernier division and  $s$  that of 1 scale division, then

$$10 v = 9 s \quad \therefore v = \frac{9}{10} s \text{ or } v = .9 s$$

$$\therefore s - v = s - .9 s = .1 s.$$

$.1 s$  is the limit of accuracy or the '*least count*' of the vernier.

*Rules for use.* (i) Note the last graduation number on S before reaching the zero on V. This is the fixed scale reading.

(ii) Note the number on V coincident with one on S.

(iii) Multiply this number by the '*least count*' and add it to the fixed scale reading. This gives the true length within the limit of accuracy of the vernier.

**B. Simple backward-reading vernier.**

The graduation numbers on V run in the *opposite* direction to those on S as shown in Fig. 1 c.

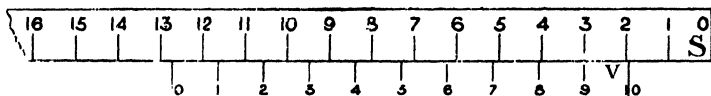

Fig. 1 c.

Here,  $10 v = 11 s$

$$\therefore v = \frac{11}{10} s$$

$$= 1.1 s$$

$$\therefore v - s = 1.1 s - s$$

$$= .1 s \text{ (least count).}$$

*Rules for use.* (i) Note the last number on S before reaching the No. 10 mark on V.

(ii) and (iii) exactly as in A.

Thus the reading in Fig. 1 c is 1.9 scale units.

**C. General theory of the vernier.**

(a) *Forward-reading.* Here  $n$  divs. on V =  $n-1$  divs. on S.

$$\text{i. o. } n v = (n-1) s \quad \therefore v = \frac{n-1}{n} s$$

$$\therefore s - v = s - \frac{n-1}{n} s \text{ or } s - v = \frac{1}{n} s.$$

$\frac{1}{n} s$  represents the *least count* or limit of accuracy.

(b) *Backward-reading.* Here  $n v = (n+1) s$

$$\therefore v = \frac{n+1}{n} s$$

$$\therefore v - s = \frac{n+1}{n} s - s \text{ or } v - s = \frac{1}{n} s.$$

**D. Vernier with 'least count' = .002 scale units.**

Fig. 1 D shows an exaggerated drawing of a vernier often attached to the inch scale of a barometer.

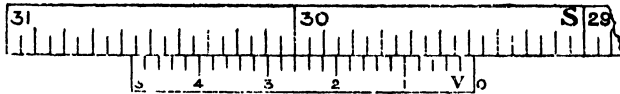

Fig. 1 D.

The scale *unit* is 1 inch ; each inch is numbered.

This *unit* is divided into  $\frac{1}{25}$ ths, but these are not numbered.

The smallest scale division ( $s$ ) is, therefore,  $\frac{1}{25}$  in. or .05 in.

$$\begin{aligned} 25v &= 24s \\ \therefore v &= \frac{24}{25}s \\ s - v &= s - \frac{24}{25}s \\ &= \frac{1}{25}s \\ &= \frac{1}{25} \times \frac{1}{20} \text{ in.} \\ &= \frac{1}{500} \text{ in.} = .002 \text{ in. (least count).} \end{aligned}$$

*Rules for use.* (i) and (ii) As in *A*.

(iii) The 5th, 10th, 15th, 20th, and 25th vernier divisions are marked 1, 2, 3, 4, 5.

These numbers indicate the number of  $\frac{1}{25}$ ths of an inch to be added to the fixed scale reading if coincidence occurs there. Thus length from zero to 5th div. on V (= No. 1) is less than  $5 \times \frac{1}{20}$  in. by  $5 \times .002$  in., i. e. by .01 in.

Hence if coincidence occurs at No. 1 V, add .01 in. to fixed scale reading ; if at No. 1.4 V, add .01 +  $4 \times .001 = .014$  in.

The fixed scale reading in Fig. 1 D is 29.35 in.

Coincidence occurs at 2.6 on V,  $\therefore$  add .026 in.

Final reading = 29.376 in.

**E. Vernier with 'least count' = .05 small scale divisions.**

Fig. 1 E shows a vernier such as is attached to arcs of circles on surveying instruments. The scale *unit* is  $1^\circ$ .

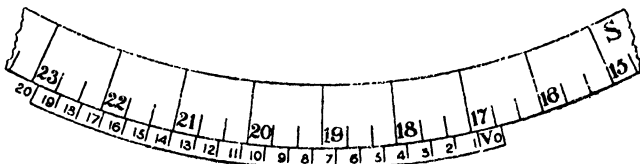

FIG. 1 E.

Each of these is numbered, and is divided into three. Hence the smallest scale *division* is  $20'$ .

$$20 v = 19 s \quad \therefore v = \frac{19}{20} s = \frac{19}{20} \text{ of } 20' = 19'$$

$$\therefore s - v = \frac{1}{20} s = .05 s \text{ (in this case) } = 1'$$

To use it, read the number on S to the last third of a degree before the zero of V, i. e.  $16^\circ 20'$  (Fig. 1 E). Add the number of coinciding mark on V, i. e. 15, to the minutes, obtaining  $16^\circ 35'$  as the correct reading.

### QUESTIONS ON VERNIERS.

1. A fixed scale is divided into inches and twentieths. How would you construct a vernier scale to read to  $\frac{1}{180}$  in. ?

2. Construct a vernier on paper to read to .1 cm. with a cm. scale ; and another to read to  $\frac{1}{32}$  inch with an inch scale divided into eights.

3. With vernier and scale as in Fig. 1 D state the reading of a barometer when the top of the mercury is (a) over 29 in., (b) between the 15th and 16th small scale divisions, and (c) when coincidence is at the 17th vernier division.

4. Find (a) the least count and (b) the readings in the follow-



ing cases. (The abbreviations are the same as those used in the previous paragraph.)

Reading on scale to nearest number.	Reading and size of small scale divisions.	Relation of $v$ to $s$ .	Coincidence on the vernier at division
15 cm.	7 ; mm.	$10 v = 9 s$	8
13 cm.	3 ; mm.	$10 v = 11 s$	6
2 in.	3 ; $\frac{1}{16}$ in.	$8 v = 7 s$	5
4	5 ; $\frac{1}{16}$ in.	$9 v = 10 s$	4
8 degrees	2 ; 20'.	$20 v = 21 s$	7
12 degrees	1 ; 15'.	$45 v = 44 s$	$1\frac{2}{3}$

5. A circle is divided into half-degrees. How would you construct a vernier to read to minutes?

6. Where would coincidence be with a vernier reading to .1 mm. when the length measured is 5.37 cm. ?

### THE SPHEROMETER<sup>1</sup>.

This instrument is on the same principle as a screw-gauge, and consists essentially of a fine vertical screw working in a collar supported by a tripod, the feet of which form an equilateral triangle. To the upper end of the screw is attached a graduated disk having 50, 100 or 500 divisions. The pitch<sup>2</sup> of the screw is usually .5 mm., so that two complete turns of the screw and disk are required to make the end of the screw move through 1 mm. A vertical mm. scale is fixed to the tripod.

<sup>1</sup> To follow Exp. 6, p. 18.

<sup>2</sup> The pitch of a screw is the distance from thread to thread measured parallel to the axis of the screw.

**Exp. 6 (b), Chap. I. To use a spherometer.**

*Required:—Spherometer, small thin metal sheets, flat sheet of plate glass 3 in. square.*

**DIRECTIONS.**

A. Examine the instrument carefully and **note**:—

- (a) the fixed scale and its graduations, especially the zero mark ;
- (b) the distance the graduated circle moves along the fixed scale during two complete turns ;
- (c) the number of graduations on the disk and how they are marked ;
- (d) the limit of accuracy.

B. Find whether there is a *zero error* as follows:—

Place the spherometer on a piece of smooth plate glass, and turn the screw until its point touches the plate and until the instrument rocks when tapped. The screw must now be turned back *until the rocking just stops*. Then the point of the screw and the ends of the three legs are all in the same plane. Note the reading on the disk.

Repeat this twice, and find the *mean zero error*.

C. Measure the thickness of a metal sheet by first determining (as above) the reading when the point of the screw and the three tripod feet are in the same plane.

Then raise the point of the screw, place the small metal sheet beneath it, and readjust the screw as before. Take three readings (readjusting the screw each time) and find the mean.

The difference between the two *mean* readings gives the thickness of the metal sheet.

**LABORATORY NOTES.**

Make a careful drawing and write a description of the instrument and state how to use it.

Record your results.

## PROBLEM.

Find the radius of curvature of a sphere or lens by finding—

(a) the reading when the screw-point is in the plane of the feet ;

(b) when placed on the sphere or lens ;

(c) the distance between the feet of the tripod.

If  $h$  is the difference between readings (a) and (b), and  $l$  is the distance between the feet, the radius of curvature  $r$  of this

sphere is  $\frac{l^2}{6h} + \frac{h}{2} = r$ .

The foregoing formula is arrived at thus:—

In Fig. 1 r suppose  $MPN$  is the sphere,  $Q$  is the point of contact of the screw and  $M$  a foot of the tripod. Draw the diameter through  $Q$ , and  $MN$  perpendicular to it.

Then rectangle  $QR \cdot RP$

$$= \text{rect. } MR \cdot RN$$

$$= \text{sq. on } RN.$$

If radius of sphere =  $r$ ;  $QR = h$ ;

$$RN = d$$

$$\text{then } h(2r - h) = d^2$$

$$\therefore r = \frac{d^2}{2h} + \frac{h}{2}.$$

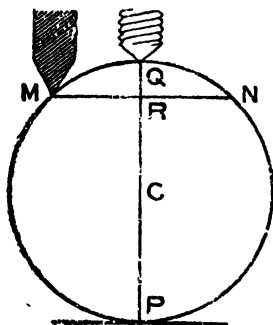

FIG. 1 r.

The feet of the tripod form an equilateral triangle inscribed in a circle of radius  $d$ .

If  $l$  is the distance between two feet,  $l = \sqrt{3}d$ ,

$$\text{hence } r = \frac{l^2}{6h} + \frac{h}{2}.$$

CALIBRATION OF TUBES AND VESSELS<sup>1</sup>.

Since tubes are drawn out from a mass of liquid glass their diameter is rarely constant. The object of calibration is to find the average diameter or calibre. In the case of tubes or vessels already graduated into equal linear

<sup>1</sup> To precede Examples on p. 85.

divisions the object is to find whether the volumetric capacity represented on the scale is correct, and if not, to find how far it is wrong.

The principle adopted, in most cases, with open tubes or vessels, is to fill the whole (or a known length) with a liquid (preferably a heavy one which does not wet the tube) of known density. The liquid used is weighed and its volume found. If the length of tube is known the *average* area of cross-section can be found, and from this the diameter can be calculated. This method is more accurate and convenient than the use of calipers, wedges, &c.

For vessels already graduated the errors at various parts can be plotted on squared paper and the error added or subtracted, as the case may be, from the subsequent readings on the vessel whenever it is used.

**Exp. 7, Chap. V. To find the internal dimensions of a piece of narrow glass tube.**

*Required:—Mercury, balance, crucible, shallow trough, glass tube, sliding calipers.*

DIRECTIONS.

Weigh a clean crucible.

Take a piece of narrow glass tube, and cut off a small portion, about 5 cm.

Pour some mercury into a trough and place the tube in the mercury so that it is filled.

Close the ends of the tube with your fingers and pour out the mercury into the crucible.

Find the weight of the mercury.

Calculate its volume assuming sp. g. of mercury is 13.6.

Measure the length of the tube with sliding calipers.

Hence calculate the area of cross-section and the diameter.

LABORATORY NOTES.

Description and measurements.

Record any errors which you think may affect your results.

**Exp. 8, Chap. V. To calibrate a narrow glass tube.**

*Required:—As in Exp. 7, and glass tube 20 cm long and 2 mm. wide; rubber tube.*

#### DIRECTIONS.

The object is to find the area of cross-section for short distances along the tube, not the mean area for the whole length.

See that the tube is clean, and introduce a thread of mercury about 2 cm. long, placing it near one end. Attach a piece of rubber tube to the end. (Mark the starting-end with a file scratch.)

Measure the length of the thread with sliding calipers carrying a vernier. Also note the distance of the middle point of the thread from the end of the tube.

Close the rubber tube and pinch it till the mercury moves on a distance approximately equal to its own length.

Measure (*a*) its length, (*b*) distance of its middle point from end of tube.

Continue this till the mercury arrives at the opposite end of the tube.

Then transfer the mercury to a weighed crucible, and weigh it.

Calculate its volume (*V*).

#### LABORATORY NOTES.

Record results thus:—

Distance from end of tube to middle of thread.	Length of thread ( <i>L</i> ).	Area of cross-section $= \frac{V}{L}$ .

Plot a curve thus. Draw a horizontal line on squared paper equal to length of the tube and mark on it the distances given

in the first column. Erect ordinates at these points and mark off on each a length proportional to the cross-section at that point of the tube (subtracting a constant number from each). Choose a large unit. Join the end of these ordinates by a smooth curve.

**Exp. 8, Chap. V. To calibrate burettes, pipettes, measuring jars, &c.**

*Required :—Balance, porcelain dish, and above vessels.*

#### DIRECTIONS.

Use water. For a *pipette*, fill it, run out water as described on p. 35 into a weighed basin.

Calculate the volume of the water by dividing its weight by its density at the temperature of the room.

*For burettes or measuring jars*, transfer successive scale volumes (say 10 c.c.) of water to the weighed dish. Make a table of corrections as before.

## ANSWERS TO EXAMPLES

### Examples I (a), page 19.

10. 555.5 cm.
11. (a) 1.6093 Km.                      (b) 8.046 Km.
12. (a) 3.0159 m.                      (b) 331.3
13. 100.14 cm.

### Examples I (b), page 25.

1. 10,000                                      (b) 10,000,000,000                      (c) 100
2. (a) 14,369,200                      (b) .00143692                      (c) .143692
3. 90,000
4. (a) 11,207.8 sq. cm.                      (b) 1.12078 sq. m.
5. (a) .36 sq. m.                      (b) 3,600 sq. cm.
6. 292.8 sq. cm.
7. 6.5 dm.
8. 76.25 m.
9. 648.85 sq. m.
10. 6.25 sq. cm.
11. (a) 28.2744 sq. cm.                      (b) 7.0686 sq. cm.
12. 16.968 mm.
13. 6 cm.

### Examples I (c), page 36.

3. 53.927 l.
4. 500 c. mm.
5. (a) 3675 c.c.                      (b) 3.675 l.
6. 117.48 c.m.
7. 29.41 cm.
8. 37.3065 c.c.

9. 6.66 sq. cm.
10. 10 sq. mm.
11. 15.625 c.c. ; 27 l.
12. 1000 m.

**Questions on Chap. III, page 60.**

5.  $37.7^{\circ}\text{C.}$  ;  $-17.7^{\circ}\text{C.}$  ;  $-35.5^{\circ}\text{C.}$
6.  $104^{\circ}\text{F.}$  ;  $413.6^{\circ}\text{F.}$  ;  $89.6^{\circ}\text{F.}$  ;  $14^{\circ}\text{F.}$

**Page 63.**

- (1) 12 cm.                      (2) 9.33 g.

**Examples IV, page 68.**

5. (a) 308,130.71 cg.              (b) 3.0813071 Kg.
6. (a) 2023.54 g.                  (b) 2.02354 Kg.
7. 2.62 g.
8. 25.664 g.
9. 5.452 g.
10. 11.8095 g.
11. 100.
12. 7.0875 g.
13. 20.65 mg.
14. (a) 453.6 g.                      (b) 1016.064 Kg.
15. 33.333 sq. cm.
16. 1.163 g.
17. 142.3 c.c.

**Questions on Chap. V, page 85.**

$$(\pi = 3.1416)$$

1. 7.58 g. per c.c.
2. 111.1 c.c.
3. .8.
4. 13.6.
5. 9.06 g. per c.c. (approx.)
8. 13.807 g.
9. 5263.16 sq. cm.
10. 9.579 g.
11. 316.8 g.



12. 3078 g. per sq. cm.
13. 1.23.
14. .2376.
15. 2.68.
16. 2.7.
17. 28.18.
18. 8.606 g. per c.c.

**Examples VI (a), page 103.**

1. 34.7.
3. (a) 73.5. (b) 14° C.
5. 39.8 g.
6. At 19° C. 1.14 ; at 30° C. 1.43.
7. 38.6 g. of salt ; 1.4 g. of lead chloride.

**Questions on Chap. VII, page 124.**

9. 36.3 per cent.

**Examples VIII (a), page 132.**

1. 288° A. ; 258° A. ; 273° A. ; 546° A. ; 0° A.
2. 110.14 c.c.
3. 3052.08 c.m.
4. .929 l.
5. .5.
6. 91° C.
7. 775.1 c.c. ; .00129 g.
8. 154.8 Kg.
9. .0549 l. ; 1.222 g.
11. 74.005 g.

**Examples VIII (b), page 141.**

1. (a) 97.4 c.c. ; (b) 102.7 c.c.
2. 18.75 cm. of mercury.
3. 1033.6 cm.
4. 6.857 litres.
5. (a) 17.5 cub. ft. ; (b) 13.125 cub. ft.
6. 323.8 inches.

7. .0257 l.
8. 380 mm. of mercury.
9. 2280 mm. of mercury or 3 atmospheres.
10. (a) 550 mm. of mercury. (b) 132 c.c.
11. (a) 735.3 mm. (b) 176.47 c.c.

**Examples VIII (c), page 144.**

1. 78.44 c.c.
2. 15.95 l.
3. 16.77 l. (approx.)
4. 76.91 cub. in.
5. 31.21 inches.
6. Increase of 2.74 lb. per sq. in.
7. (a) 15.7 c.c. (b) 17.1 c.c.
8. 1.209704 g.
9. (a) .0012932 (approx.); (b) 8 Km. (approx.)
10. Reduced to 55.9 cm. of mercury.

**Examples IX, page 152.**

1. 605 mm. ; 39.8 c.c.
2. 743.9 mm.
3. 592.3 mm. ; 38.96 c.c.
7. 102.3 c.c.
8. 17.2 g.

**Examples X, page 160.**

Temperatures are given approximately to one decimal place.

1. (a) 56.4° C. (b) 63° C. (c) 20° C.
2. (a) 800 calories. (b) 5,000 calories.
3. 1,111.1 calories.
4. (a) 1,250 units. (b) 900 units.
7. (a) 380 cal. (b) 470 cal. (c) 247.5 cal.
8. .053. 9. 22.9° C. 10. 6.13 cal.

**Revision Questions, page 168.**

23. 161.9 c.c. (approx.)

**Page 169.**

25. 600 c.c.

26. 15 cm.

27. 1:13.6; 163.2.

33. (a) 36.2 (approx.).                      (b) 29.55 g.

**Page 170.**

44. 747.3 mm.

## INDEX TO PART I

- Accuracy, degree of, 3.  
Air, to measure the expansion of, 128; some properties of, 125-43.  
Apparatus, hints on fitting up, 46.  
Archimedes, principle, 79.  
Area, measurement of, 20-5.  
Area of a circle, 22.  
Area of cross-section of a narrow tube, 24, 25.
- Balance, to adjust a, 64.  
Barometer, 135, 136.  
Batswing burner, 38.  
Boiling-point of a liquid, to find the, 59, 151.  
Boyle's law, 140.  
Bunsen burner, 37, 38.  
Burette, 32-4.
- Calibration of tubes and vessels, 177-80.  
Calipers, 16, 17.  
Calorie, 156.  
Chemical balance, Chap. IV, 61-8.  
Cork, to bore a, 44.  
Crystallization, conditions of, 114; water of, 118.  
Crystals, the effect of heat on, 115-17; to measure the angles of, 110.  
Curve of solubility, to plot a, 101, 102.
- Decantation, 89.  
Deliquescence, 122.  
Density, def., 72; measurement of, 69-85; relative, 74.  
Desiccator, 122.  
Distillation, 92-4.  
Drying a flask, 45.
- Ebullition, 149.  
Efflorescence, 122.  
Error of parallax, 30.  
Evaporation, 89, 149.
- Filtration, 88.  
Fixed points of a thermometer, 53, 54.  
Fortin's barometer, 136.  
Fractional distillation, 106.
- Gases, identification of, 163.  
Glass working, 39-43.
- Heat, measurement of, 153-9; simple effects of, 48-60.
- Identification of substances, 161-4.  
Iron pyrites, 111.
- Latent heat, 55, 56.  
Law of Boyle, 140.  
Law of Charles, 130, 131.  
Law of partial pressures, 148.  
Length, measurement of, 2-18.  
Liebig's condenser, 93.  
Liquids, identification of, 162, 163.
- Measuring jar, to use, 28, 29.  
Melting-point of a solid, 57.  
Meniscus, 30.  
Metric system, 1, 2.  
Metric tables, 2.
- Notes, rules for writing, 4, 5.
- Parallax, error of, 30.  
Pipette, 35.  
Pressure of solids and liquids, 83.  
Pressure, transmission of, 83-5.
- Quartz, 111.
- Ratio of circumference to diameter of a circle, 14.  
Relative density, 74.  
Relative density bottle, to use, 75.  
Rider, 66, 67.

- Rock crystal, 111.  
Rock salt, 111.  
Rules for weighing, 65.
- Screw gauge, 17, 18.  
Selenite, 111.  
Solids, identification of, 161, 162.  
Solubility curve, 101.  
Solubility, def., 98.  
Solubility of solids, to determine, 99.  
Solutions, 87-108 ; saturated solution, 91 ; super-saturated solution, 114.  
Specific gravity, 72, 73.  
Specific heat, 158.  
Specific properties, 162.
- Spherometer, 175-7.  
Standard of length, 1.  
Still, 94.  
Sublimation, 118.  
Sulphur crystals, to make, 123.
- Thermometer, the centigrade, 51.
- Unit of heat, 155.
- Vapour pressure, 147.  
Verniers, types of, 15, 16, 171-4.  
Volatility, 118.  
Volume, measurement of, 26-35.
- Water vapour, influence of temperature on the pressure of, 150.  
Weighing, rules for, 65.

**OXFORD**  
**PRINTED AT THE CLARENDON PRESS**  
**BY HORACE HART, M.A.**  
**PRINTER TO THE UNIVERSITY**

**OXFORD UNIVERSITY PRESS**

**PUBLICATIONS IN NATURAL SCIENCE  
AND MATHEMATICS**





# NATURAL SCIENCE

## Botany

Series of Botanical Translations, under the general editorship of Professor I. BAYLEY BALFOUR

Royal 8vo, unless otherwise specified. The prices are for copies with morocco back and copies in cloth respectively.

**Jost's Lectures on Plant Physiology.** Authorized English translation by R. J. HARVEY GIBSON. 21s. net and 21s. net.

**Schimper's Geography of Plants,** authorized English translation by W. R. FISHER, revised by P. GROOM and I. BAYLEY BALFOUR. With maps, collotypes, portrait, and 497 other illustrations. Morocco back, £2 2s. net.

**Pfeffer's Physiology of Plants,** a treatise upon the Metabolism and Sources of Energy in Plants. Second fully revised Edition, translated and edited by A. J. EWART. Vol. I, £1 6s. net and £1 3s. net. Vol. II, 16s. net and 14s. net. Vol. III completing the work, £1 1s. net and 18s. net.

**Goebel's Organography of Plants.** Authorized English Edition by I. BAYLEY BALFOUR. PART I, General. 12s. net and 10s. net. PART II, Special. 24s. net and 21s. net.

**Goebel's Outlines of Classification and Special Morphology of Plants.** Translated by H. E. F. GARNSEY, and revised by I. BAYLEY BALFOUR. Morocco back, £2 2s. net (a few copies only remain).

**Sachs's History of Botany (1530-1860).** Translated by H. E. F. GARNSEY, revised by I. B. BALFOUR. 2nd impression. Cr. 8vo, cloth, 10s. net.

**A History of Botany, 1860-1900:** a continuation of Sachs's History. By J. REYNOLDS GREEN. Crown 8vo. 9s. 6d. net.

**De Bary's Comparative Anatomy of the Vegetative Organs of the Phanerogams and Ferns.** Translated by F. O. BOWER and D. H. SCOTT. £1 4s. net and £1 1s. net.

**De Bary's Comparative Morphology and Biology of Fungi, Mycetozoa and Bacteria.** Translated by H. E. F. GARNSEY, revised by I. BAYLEY BALFOUR. £1 4s. net and £1 1s. net.

**De Bary's Lectures on Bacteria.** Second edition. Translated by H. E. F. GARNSEY, revised by I. BAYLEY BALFOUR. Crown 8vo, cloth, 5s. net.

**Solms-Laubach's Introduction to Fossil Botany.** Translated by H. E. F. GARNSEY, revised by I. BAYLEY BALFOUR. 17s. net and 15s. net.

**Fischer's Bacteria,** translated by A. COPPEN JONES. Cloth, 7s. 6d. net.

**Knuth's Handbook of Floral Pollination,** based upon Hermann Müller's work, *The Fertilization of Flowers by Insects*, translated by J. R. AINSWORTH DAVIS. Vol. I, 21s. net and 18s. net. Vol. II, 35s. net and 31s. 6d. net. Vol. III, 31s. 6d. net and 28s. net.

**Solereeder's Anatomy of the Dicotyledons.** Translated by L. A. BOODLE and F. E. FRITSCH. Revised by D. H. SCOTT. Two volumes, 27s. 6d. net each and 24s. net each.

**Warming's Oecology of Plants.** English edition by P. GROOM and I. B. BALFOUR. 10s. net and 8s. 6d. net.

**On the Physics and Physiology of Protoplasmic Streaming in Plants.** By A. J. EWART. With 17 illustrations. 8s. 6d. net.

**List of British Plants.** By G. C. DRUCE. Crown 8vo, paper covers. 2s. 6d. net; cloth interleaved, 3s. 6d. net.

## CLARENDON PRESS BOOKS

---

### **Floral Mechanism : Diagrams and Descriptions of Common Flowers.**

By A. H. CHURCH. Royal 4to. Part I, Types I-XII (Jan. to April). With coloured plates and numerous other figures. 21s. net.

### **Index Kewensis; an enumeration of the Genera and Species of Flowering**

Plants from the time of Linnaeus to the year 1885. Edited by Sir J. D. HOOKER and B. D. JACKSON. 2 vols. 4to, morocco back, £10 10s. net.

Supplement I (1886-1895), can be ordered from Mr. Frowde, price with the Index £12 13s. net; it is not sold separately. Supplement II (1896-1900), 28s. net. Or Fasc. I, 12s. net; Fasc. II, 12s. net. Supplement III (1901-1905), 28s. net.

### **Annals of Botany.** Edited by I. BAYLEY BALFOUR, D. H. SCOTT,

J. B. FARMER, and R. THAXTER; assisted by other Botanists. Royal 8vo, morocco back, with many plates and illustrations in the text. Subscription price for each four parts, 30s., with 1s. 6d. for foreign postage.

Vol. I, Nos. 1-4. Sold only as part of a complete set.

Vol. II, Nos. 5-8. Sold only as part of a complete set.

Vol. III, Nos. 9-12. £2 12s. 6d. Vol. IV, Nos. 13-16. £2 5s.

Vol. V, Nos. 17-20. £2 10s. Vol. VI, Nos. 21-24. £2 1s.

Vol. VII, Nos. 25-28. £2 10s.

Vol. VIII, Nos. 29-32. £2 10s.

Vol. IX, Nos. 33-36. £2 15s.

Vol. X, Nos. 37-40. Vol. XI, Nos. 41-44.

Vol. XII, Nos. 45-48. Vol. XIII, Nos. 49-52.

Vol. XIV, Nos. 53-56. Vol. XV, Nos. 57-60.

Vol. XVI, Nos. 61-64, including a Life of Sir WILLIAM HOOKER, with a photogravure portrait.

Vol. XVII, Nos. 65-68. Vol. XVIII, Nos. 69-72.

Vol. XIX, Nos. 73-76. Vol. XX, Nos. 77-80.

Vol. XXI, Nos. 81-84. Vol. XXII, Nos. 85-88.

Vol. XXIII, Nos. 89-92. Vol. XXIV, Nos. 93-96.

(The price of a volume is £2 16s. unless stated.)

### **Indexes to the Annals of Botany.** Prepared by T. G. HILL, under

the direction of the Editors. Royal 8vo. (1) Vols. I-X. (2) Vols. XI-XX. Each, paper covers, 5s. to subscribers; to non-subscribers, 9s.; morocco back, to subscribers, 6s.; to non-subscribers, 10s. 6d.

Reprint: Life of Sir WILLIAM HOOKER, with portrait, 3s. 6d. net.

### **The Flora of Berkshire; with short Biographies of the Berkshire**

Botanists. By G. C. DRUCE. Crown 8vo. 16s. net.

### **The Herbarium of the University of Oxford.** By the same.

Crown 8vo. 6d.

### **The Dillenian Herbaria.** By G. C. DRUCE. Edited with Introduction

by S. H. VINES. Crown 8vo. 12s. 6d. net.

### **Studies in Forestry.** By J. NISBET. Crown 8vo. 6s. net.

### **Forest Terminology (French-German-English).** By W. R. FISHER.

[In the press.]

### **The Physical Properties of Soil.** By R. WARINGTON. 8vo. 6s.

### **School Gardening.** By P. ELFORD and S. HEATON. Crown 8vo, illustrated. 2s. net.

### **A School Garden Note-Book.** By PERCY ELFORD and S. HEATON. Crown 8vo. 9d. net.

# NATURAL SCIENCE

---

## Biology

**Essays on Evolution.** By E. B. POULTON. 8vo. 12s. net.

**Physiological Histology.** By G. MANN. 8vo. 15s. net.

**Experimental Embryology.** By J. W. JENKINSON. 8vo. 12s. 6d. net.

**Adler's Alternating Generations ; a Biological Study of Oak Galls and Gall Flies.** Translated and edited by C. R. STRATON. With coloured illustrations of 42 Species. Crown 8vo. 10s. 6d. net.

**The Birds of Oxfordshire.** By O. V. APLIN. 8vo. 7s. 6d. net.

**The Harlequin Fly : its Structure and Life-History.** By L. C. MIALL and A. R. HAMMOND. With one hundred and thirty illustrations. 8vo. 7s. 6d.

**A Naturalist in Tasmania.** By G. W. SMITH. 8vo, illustrated. 7s. 6d. net.

**Müller's Vocal Organs of the Passeres,** translated by F. J. BELL, and edited by A. H. GARROD. With plates. 4to. 7s. 6d.

**A Glossary of Greek Birds.** By D'ARCY W. THOMPSON. 8vo. 10s. net.

**The Order Oligochaeta, a Monograph, Structural and Systematic.** By F. E. BEDDARD. With illustrations. Demy 4to. £2 2s. net.

**Memoirs on the Physiology of Nerve, of Muscle, and of the Electrical Organ.** Edited by Sir J. BURDON-SANDERSON. Medium 8vo. £1 1s.

**Ecker's Anatomy of the Frog.** Translated, with Additions, by G. HASLAM. Medium 8vo. £1 1s.

**Weismann's Essays upon Heredity.** Authorized Translation. Crown 8vo. Vol. I. Ed. E. B. POULTON, S. SCHÖNLAND, and A. E. SHIPLEY. Ed. 2. 7s. 6d. Vol. II. Ed. E. B. POULTON and A. E. SHIPLEY. 5s.

**Catalogue of Eastern and Australian Lepidoptera Heterocera in the Oxford University Museum.** By Colonel C. SWINHOE. Part I : 8vo, with eight plates, £1 1s. Part II : by Col. C. SWINHOE, Lord WALSHINGHAM and J. H. DURRANT. With eight plates, £2 2s.

**African Mimetic Butterflies.** By H. ELTRINGHAM. With ten coloured plates and a map. Royal 4to. £2 10s. net.

**Forms of Animal Life, a manual of comparative Anatomy.** By G. ROLLESTON. Second edition. Medium 8vo. £1 16s.

**Rolleston's Scientific Papers and Addresses.** Edited by W. TURNER. With biographical sketch by E. B. TYLOR. 2 vols. 8vo. £1 4s.

**Nature and Man.** By Sir E. RAY LANKESTER (being the Romanes Lecture, 1905). 8vo, paper covers. Third impression. 2s. net.

**An Introduction to the Study of Biology.** By J. W. KIRKALDY and I. M. DRUMMOND. Crown 8vo, illustrated. 6s. 6d.

---

**Lectures on the Method of Science.** Edited by T. B. STRONG. 8vo. 7s. 6d. net.

**Rivers and Canals.** By L. F. VERNON-HARCOURT. 2 vols. 8vo. 31s. 6d

## CLARENDON PRESS BOOKS

---

### Medicine and Hygiene

- Quarterly Journal of Medicine.** Edited by WILLIAM OSLER, J. ROSE BRADFORD, R. HUTCHISON, A. E. GARROD, H. D. ROLLESTON, and W. HALE WHITE. 8s. 6d. net per number. Annual Subscription, 25s. Vol. I (Nos. 1-4), Vol. II (Nos. 5-8), Vol. III (Nos. 9-12), 35s. net each.
- Studies in the Medicine of Ancient India.** By A. F. R. HOERNLÉ. 8vo. Part I: Osteology. Illustrated. 10s. 6d.
- Surgical Instruments in Greek and Roman Times.** By J. S. MILNE. With illustrations. 8vo. 14s. net.
- English Medicine in Anglo-Saxon Times: the Fitz-Patrick Lectures for 1903.** By J. F. PAYNE. 8vo, with 23 illustrations. 8s. 6d. net.
- The Study of Medicine in the British Isles: Fitz-Patrick Lectures, 1905-6.** By NORMAN MOORE. 8vo, with 13 Collotype plates. 10s. 6d. net.
- The Last Days of Charles II.** By RAYMOND CRAWFURD. Medium 8vo, illustrated. 5s. net.
- An Alabama Student and other Biographical Essays.** By WILLIAM OSLER. 8vo, with portraits and other illustrations. 7s. 6d. net.
- Two Oxford Physiologists (Lower and Mayow).** By FRANCIS GORCH. 8vo. 1s. net.
- Criminal Responsibility.** By CHARLES MERCIER. 8vo. 7s. 6d. net.
- The Construction of Healthy Dwellings.** By Sir D. GALTON. Second edition. 8vo. 10s. 6d.
- Healthy Hospitals.** By the same, with illustrations. 8vo. 10s. 6d.
- A System of Physical Education: Theoretical and Practical.** By A. MACLAREN. New edition, by W. MACLAREN. Crown 8vo. 8s. 6d. net. Pathological Series in the Oxford Museum. By Sir H. W. ACLAND. 8vo. 2s. 6d.
- Epidemic Influenza.** By F. A. DIXEY. Medium 8vo. 7s. 6d.
- Scarlatina.** By D. A. GRESSWELL. Medium 8vo. 10s. 6d.
- Surgical Aspect of Traumatic Insanity.** By H. A. POWELL. 8vo. 2s. 6d.

### The Oxford Medical Publications

PUBLISHED BY

HENRY FROWDE AND HODDER & STOUGHTON

(A complete list may be had on application.)

- The Collected Writings of the Right Hon. Lord Lister, O.M., F.R.S.** In two volumes. Demy 4to. 42s. net.
- The History of Medicine.** By Prof. MAX NEUBERGER. Translated by ERNEST PLAYFAIR. In 2 volumes. Crown 4to. Vol. I now ready. 25s. net.
- Practical Pathology.** By G. SIMS WOODHEAD. Fourth edition. Illustrated by over 240 microscopical drawings in colour. Demy 8vo. 31s. 6d. n.
- Clinical Pathology in General Practice.** By T. J. HORDER. Demy 8vo. 7s. 6d. net.
- A System of Medicine.** Edited by WILLIAM OSLER, F.R.S., and THOMAS McCRAE. In seven 8vo volumes of about 900 pages each illustrated. Price to subscribers for the seven volumes 21s. net each volume; to non-subscribers, single volumes, 30s. net.

## MEDICINE AND HYGIENE

---

- A System of Diet and Dietetics.** From the scientific and practical standpoint. Edited by G. A. SUTHERLAND. Crown 4to. 30s. net.
- A System of Operative Surgery.** Edited by F. F. BURGHARD. Now ready, complete in four vols. Cr. 4to. £6 net the set, or 36s. net each vol.
- Fevers in the Tropics.** By LEONARD ROGERS, I.M.S. Cr. 4to. Ed. 2. 30s. n.
- Heart Diseases.** By JAMES MACKENZIE. 2nd ed. Cr. 4to. 25s. net.
- Heart Diseases—Graphic Methods.** By JOHN HAY. 7s. 6d. net.
- Text-book of Anatomy.** Edited by D. J. CUNNINGHAM, F.R.S. Third edition. Royal 8vo. 31s. 6d. net.
- Manual of Practical Anatomy.** By D. J. CUNNINGHAM, F.R.S. Fourth edition. In two volumes. Crown 8vo. 10s. 6d. net each.
- Manual of Surgery.** By ALEXIS THOMSON and ALEXANDER MILES. Third edition. Two vols. Crown 8vo. 10s. 6d. net each.
- Manual of Operative Surgery.** By H. J. WARING. Third edition. 521 Illustrations, including 30 in colour. Crown 8vo. 12s. 6d. net.
- Operations of General Practice.** By EDRED M. CORNER and HENRY IRVING PINCHES. Third edition. Demy 8vo. 15s. net.
- Fractures and their Treatment.** By J. HOGARTH PRINGLE. Royal 8vo. 15s. net.
- A Handbook of the Surgery of Children.** By Prof. E. KERMISSON. Translated by J. KEOGH MURPHY. 8vo. 20s. net.
- Emergencies of General Practice.** By P. SARGENT and A. E. RUSSELL. Demy 8vo. 15s. net.
- Infectious Diseases.** By C. B. KER. Crown 4to. 20s. net.
- Manual of Bacteriology.** By ROBERT MUIR and JAMES RITCHIE. Fifth edition, thoroughly revised. With nearly 200 illustrations in the text and 20 figures in colour. Crown 8vo. 10s. 6d. net.
- A Laboratory Handbook of Bacteriology.** By R. ABEL. Translated by M. H. GORDON, from the Tenth (German) Edition. Cr. 8vo. 5s. net.
- Functional Nervous Disorders in Childhood.** By LEONARD G. GUTHRIE. Second impression. Crown 8vo. 7s. 6d. net.
- Common Disorders and Diseases of Childhood.** By G. D. STILL. Demy 8vo. Second Impression. 15s. net.
- The Blood in Health and Disease.** By R. J. M. BUCHANAN. Demy 8vo. 12s. 6d. net.
- Sprains and Allied Injuries of Joints.** By R. H. A. WHITELOCKE. Demy 8vo. Second edition. 7s. 6d. net.
- Medical Inspection of Schools.** By A. H. HOGARTH. Cr. 8vo. 6s. n.
- Introduction to Practical Chemistry.** By A. M. KELLAS. Demy 8vo. 3s. 6d. net.
- Practical Inorganic Chemistry.** By A. M. KELLAS. Demy 8vo. 5s. n.
- Outlines of Zoology.** By J. ARTHUR THOMSON. Fifth Ed. Revised and Enlarged. Crown 8vo. 12s. 6d. net.

### IN PREPARATION

**The Surgery of the Skull and Brain.** By L. BATHE RAWLING.

## CLARENDON PRESS BOOKS

---

### Oxford Medical Manuals

Edited by J. KEOGH MURPHY. Crown 8vo. 5s. net each volume.

**Diseases of the Larynx.** By H. BARWELL. **Treatment of Disease in Children.** By G. A. SUTHERLAND. **Surgical Emergencies.** By P. SARGENT. **Skin Affections in Childhood.** By H. G. ADAMSON. **Heart Disease.** By F. J. POYNTON. **Practical Anaesthetics.** By H. E. G. BOYLE. **Diseases of the Ear.** By HUNTER TOD. **Diseases of the Nose.** By E. B. WAGGETT. **Diseases of the Eye.** By M. S. MAYOU. **Gunshot Wounds.** By Major C. G. SPENCER. **Infant Feeding.** By J. S. FOWLER. **Aseptic Surgery.** By C. B. LOCKWOOD. **Gallstones, their Complications and Treatment.** By A. W. MAYOROBSON and P. J. CAMMIDGE. **The Law in General Medical Practice.** By S. ATKINSON. **Glandular Enlargements.** By A. EDMUNDS.

### Geology

**The Face of the Earth (Das Antlitz der Erde).** By EDUARD SUESS. Translated by HERTHA B. C. SOLLAS, under the direction of W. J. SOLLAS; with a preface by Professor SUESS. Royal 8vo. In five volumes.  
Vol. I, with 6 maps and 48 illustrations. 25s. net.  
Vol. II, with 3 maps and 42 illustrations. 25s. net.  
Vol. III (- III i of the German edition), with 7 maps and 23 illustrations. 18s. net.  
Vol. IV (= III ii of the German edition), with 55 illustrations. 25s. net.

**Fossils of the British Islands, Stratigraphically and Zoologically arranged.** Part I, Palaeozoic. By R. ETHERIDGE. 4to. £1 10s.

**Martini Lister Historia sive Synopsis Methodica Conchyliorum.** Editio Tertia. Recensuit et indice locupletissimo instruxit L. W. DILLWYN. 1823. With numerous plates. 52s. 6d. net.

**First Lessons in Modern Geology.** By A. H. GREEN, edited by J. F. BLAKE. With 42 illustrations. Crown 8vo. 3s. 6d.

**Geology of Oxford and Thames.** By J. PHILLIPS. 8vo. £1 1s.

**Vesuvius.** By the same. Crown 8vo. 10s. 6d.

**Geology.** By Sir J. PRESTWICH. Royal 8vo. Vol. I. Chemical and Physical. £1 5s. Vol. II. Stratigraphical and Physical. With a geological map of Europe. £1 16s. Geological Map (separately), 5s.

**Physics of Earthquake Phenomena.** By C. G. KNOTT. 8vo, with numerous diagrams. 14s. net.

# ASTRONOMY, CHEMISTRY

## Astronomy

**Astronomy in the Old Testament.** By G. SCHIAPARELLI.  
Authorized English translation. Crown 8vo. 3s. 6d. net.

**A Handbook of Descriptive Astronomy.** By G. F. CHAMBERS. Fourth edition. In three vols. 8vo. 28s. net, or separately, Vol. I. Sun, Planets, and Comets, 15s. net. Vol. II. Instruments and Practical Astronomy, 15s. net. Vol. III. The Starry Heavens. 10s. 6d. net.

**The Story of the Comets.** By G. F. CHAMBERS. 8vo, with many illustrations. Second Edition. 6s. net.

**Bradley's Miscellaneous Works.** 4to. 17s. net.

**A Cycle of Celestial Objects, observed, reduced, and discussed** by W. H. SMYTH; revised and greatly enlarged by G. F. CHAMBERS. 8vo. 6s. net.

**Astronomical Observations made at the University Observatory,** Oxford, under the direction of C. PRITCHARD. Royal 8vo.

No. I. On observations of Saturn's Satellites. Paper covers, 3s. 6d.

No. II. A Photometric determination of the magnitudes of all Stars visible to the naked eye, from the Pole to 10° south of the Equator, 8s. 6d.

Nos. III and IV. Researches in Stellar Parallax by the aid of Photography. Part I, 7s. 6d. Part II, 4s. 6d.

**Tables for Facilitating Computation of Star-Constants.**

By H. H. TURNER. Second impression. 8vo. 2s. (published by Mr. Frowde).

**Halley's Comet.** By H. H. TURNER. 8vo. Ed. 2. Illustrated. 1s. net.

**Halley's Comet, with notes on Comets in general.** By G. F. CHAMBERS. 8vo. Illustrated. 1s. net.

**Celestial Ejectamenta: the first Halley Lecture,** by HENRY WILDE. 8vo. Illustrated. 1s. net.

## Chemistry

**Mathematical Crystallography.** By H. HILTON. 8vo. 14s. net.

**Crystallography.** A treatise on the Morphology of Crystals. By N. STORY-MASKELYNE. Crown 8vo. 12s. 6d.

**Fock's Introduction to Chemical Crystallography,** translated by W. J. POPE; preface by N. STORY-MASKELYNE. Cr. 8vo. 5s.

**The Molecular Tactics of a Crystal.** By LORD KELVIN. 8vo. 3s. 6d.

**Organic Chemistry of Nitrogen.** By N. V. SIDGWICK. 8vo. 14s. net.

**Elementary Chemistry.** Progressive Lessons in Experiment and Theory. By F. R. L. WILSON and G. W. HEDLEY. 8vo, with many diagrams. Part I. Second edition. 3s. Part II. Second edition. 5s.

**Class Book of Chemistry.** By W. W. FISHER. Ed. 5. Cr. 8vo. 4s. 6d.

**Exercises in Practical Chemistry.** By A. G. VERNON HARCOURT and H. G. MADAN. Fifth edition. Crown 8vo. 10s. 6d.

**Van 't Hoff's Chemistry in Space,** translated and edited by J. E. MARSH. Crown 8vo. 4s. 6d.

**Original Papers in the Science of Chemistry.** A list compiled by V. H. VELEY. Third edition. Paper covers, 1s.

**Chemistry for Students.** By A. W. WILLIAMSON. Fcap. 8vo. 8s. 6d.

**Tables of Qualitative Analysis.** By H. G. MADAN. 4to. 4s. 6d.

## CLARENDON PRESS BOOKS

---

### Pure and Applied Mathematics

- Introduction to the Algebra of Quantics.** By E. B. ELLIOTT. 8vo. 15s. net.
- Theory of Continuous Groups.** By J. E. CAMPBELL. 8vo. 14s. net.
- Theory of Groups of Finite Order.** By HAROLD HILTON. 8vo. 14s. net.
- Treatise on Infinitesimal Calculus.** By BARTHOLOMEW PRICE.
- Vol. I. Differential Calculus. [Out of print.]
- Vol. II. Integral Calculus, Calculus of Variations, etc. [Out of print.]
- Vol. III. Statics, including Attractions; Dynamics of a Material Particle. Second edition. 8vo. 5s.
- Vol. IV. Dynamics of Material Systems. Second edition. 8vo. 5s.
- The Collected Mathematical Papers of H. J. Stephen Smith,** late Savilian Professor of Geometry in the University of Oxford. Edited by J. W. L. GLAISHER. 2 vols. 4to. £3 3s.
- Rigaud's Correspondence of Scientific Men of the Seventeenth Century.** 1841. 2 vols. 8vo. 18s. 6d.

### Elementary Books

- Responsions Papers in Stated Subjects** (exclusive of Books), 1901-1906, with answers to Mathematical Questions and Introduction by C. A. MARCON and F. G. BRAHANT. Crown 8vo. 3s. 6d. net.
- A School Course of Mathematics.** By DAVID MAIR. Crown 8vo. 3s. 6d.
- A Study of Mathematical Education,** including the teaching of Arithmetic. By BENCHARA BRANFORD. Crown 8vo. 4s. 6d.
- School Algebra.** By W. E. PATERSON. Crown 8vo. Parts I (Ed. 3) and II (Ed. 2), each, 2s. 6d. (with answers, each 3s.); together, 4s. (with answers, 5s.).
- Arithmetic.** With or without answers. By R. HARGREAVES. Crown 8vo. 4s. 6d.
- Elementary Plane Trigonometry.** By R. C. J. NIXON. Crown 8vo. 7s. 6d.
- Book-keeping.** By SIR R. G. C. HAMILTON and J. BALL. Fcap 8vo. 2s. Ruled exercise book to the above, 1s. 6d.; to preliminary course only, 4d.
- Lectures on the Logic of Arithmetic.** By M. E. BOOLE. Crown 8vo. 2s.; or interleaved with writing-paper, 3s.
- Figures made Easy: a first Arithmetic Book.** By LEWIS HENSLEY. Crown 8vo. 6d. Answers, 1s.
- The Scholar's Arithmetic.** By the same. 2s. 6d. Answers, 1s. 6d.
- The Scholar's Algebra.** By the same. Crown 8vo. 2s. 6d.
- A Text-Book of Algebra: with Answers.** By W. S. ALDIS. Cr. 8vo. 7s. 6d.
- Elementary Mechanics of Solids and Fluids.** By A. L. SELBY. Crown 8vo. 3s. 6d.



# GEOMETRY

---

## Geometry

**Geometry for Beginners** : an easy introduction to Geometry for young learners. By G. M. MINCHIN. Extra fcap 8vo. 1s. 6d.

Elementary Geometry, on the plan recommended by the  
Mathematical Association.

**Experimental and Theoretical Course of Geometry.**

By A. T. WARREN. With Examination Papers set on the new lines. Crown 8vo. With or without answers. Third edition with additions (1905). 2s.

**Elementary Modern Geometry.** Part I. Experimental and Theoretical. (Ch. I-IV) Triangles and Parallels. By H. G. WILLIS. Crown 8vo. 1905. 2s.

**Euclid Revised**, containing the essentials of the Elements of Plane Geometry as given by Euclid in his first six books, edited by R. C. J. NIXON. Third edition. Crown 8vo. 6s.

Sold separately as follows :—Book I, 1s. ; Books I, II, 1s. 6d. ; Books I-IV, 3s. ; Books V, VI, 3s. 6d.

**Geometry in Space**, containing parts of Euclid's Eleventh and Twelfth Books. By R. C. J. NIXON. Second edition. Crown 8vo. 3s. 6d.

**Geometrical Exercises from Nixon's Euclid Revised.** With Solutions. By ALEXANDER LARMOR. Crown 8vo. 3s. 6d.

**The 'Junior' Euclid.** By S. W. FINN. Crown 8vo. Books I and II, 1s. 6d. Books III and IV, 2s.

---

**Sequel to Elementary Geometry**, with numerous examples. By J. W. RUSSELL. Cr. 8vo. 6s. **Solutions (Key)**. Cr. 8vo. 10s. 6d. net. Obtainable only from the Secretary, Clarendon Press, Oxford.

**Pure Geometry**, an elementary treatise, with numerous examples. By J. W. RUSSELL. Crown 8vo. New and revised edition (1905). 9s. net.

**Analytical Geometry**, an elementary treatise by W. J. JOHNSTON. Crown 8vo. 6s.

**Notes on Analytical Geometry.** By A. CLEMENT JONES. Crown 8vo. 6s. net.

**Cremona's Elements of Projective Geometry**, translated by C. LEUDESORF. Second edition. 8vo. 12s. 6d.

**Cremona's Graphical Statics**, being two treatises on the Graphical Calculus and reciprocal figures in Graphical Statics, translated by T. H. BEARE. 8vo. 8s. 6d.

**On the Traversing of Geometrical Figures.** By J. COOK WILSON. 8vo, with Addendum. 6s. 6d. net.

**Non-Euclidean Geometry.** By J. L. COOLIDGE. 8vo. 15s. net.

## CLARENDON PRESS BOOKS

---

### Physics

- Hermann von Helmholtz.** By LEO KOENIGSBERGER. Translated by FRANCES A. WELBY. With a Preface by Lord KELVIN. Royal 8vo, with 3 portraits. 16s. net.
- Modern Views on Matter,** being the Romanes Lecture for 1903. By Sir OLIVER LODGE. New edition. 1s. net.
- Treatise on Electricity and Magnetism.** By J. CLERK MAXWELL. Third edition. Two vols. 8vo. £1 12s.
- Notes on Recent Researches in Electricity and Magnetism.** By Sir J. J. THOMSON. 8vo. [Out of print.]
- Maxwell's Elementary Treatise on Electricity.** Edited by W. GARNETT. 8vo. 7s. 6d.
- Introduction to the Mathematical Theory of Electricity and Magnetism.** By W. T. A. ENTAGE. 2nd ed. Crown 8vo. 7s. 6d.
- The Measurement of Electrical Resistance.** By W. A. PRICE. 8vo. 6s.
- The Mathematical Theory of Electricity and Magnetism.** In two volumes. By H. W. WATSON and S. H. BURBURY. 8vo. 6s. each.  
Vol. I. Electrostatics. Vol. II. Magnetism and Electrodynamics.
- The Application of Generalized Co-ordinates to the Kinetics of a Material System.** By the same. 8vo. 2s. 6d.
- Lessons on Thermodynamics.** By R. E. BAYNES. [Out of print.]
- Elementary Treatise on Heat,** with numerous Woodcuts and Diagrams. By BALFOUR STEWART. Sixth edition, revised with Additions, by R. E. BAYNES. Crown 8vo. 8s. 6d.
- Practical Work in General Physics.** By W. G. WOOLLCOMBE. Crown 8vo. 2s. each part.  
Part I. General Physics. Out of print. Part II. Heat. Second Edition, Revised. Part III. Light and Sound. Part IV. Magnetism and Electricity. Out of print.
- The Theory of a Physical Balance.** By J. WALKER. 8vo. 3s. 6d.
- A Treatise on the Kinetic Theory of Gases.** By H. W. WATSON. Second edition. Crown 8vo. 4s. 6d.
- Acoustics.** By W. F. DONKIN. Second edition. Crown 8vo. 7s. 6d. net.
- A Treatise on Statics with Applications to Physics.** By G. M. MINCHIN.  
Vol. I. Equilibrium of Coplanar Forces. Sixth edition. 8vo. 10s. 6d.  
Vol. II. Non-Coplanar Forces. Fourth edition. 8vo. 16s.
- Hydrostatics and Elementary Hydrokinetics.** By the same. Crown 8vo. 10s. 6d.

